

HRX2D MECHANICAL VENTILATION WITH HEAT RECOVERY (MVHR) UNIT FROM DOMUS VENTILATION

TECHNICAL DATA SHEET

KEY FEATURES

- ▶ Extremely low Specific Fan Power, down to 0.57W/(l/s)
- ▶ Bluebrain control optimises the unit's functionality and performance
- ▶ Heat exchange efficiency up to 94%
- ▶ Fits inside a utility room or loft space
- ▶ Ideal for larger developments, with a floor area up to 250m²



ULTIMATE PERFORMANCE

Whilst the HRX2D is easy and quick to install, commission and maintain, it also provides Specific Fan Powers as low as 0.57W/(l/s) and a high heat exchange efficiency up to 94%; lowering Dwelling Emission Rates for a higher SAP rating. Offering control functions such as frost protection, temperature and humidity control, auto thermal bypass and independent fan speed control, the Bluebrain controller boasts a full complement of air quality and commissioning controls for improved air comfort.



Image shows the HRX2D with a highly efficient heat exchanger

HRX2D PRODUCT CHARACTERISTICS DATABASE (SAP 2012)

	Thermal Bypass	Air Flow (l/s)	Specific Fan Power W/(l/s)	Heat Exchange Efficiency (%)
Kitchen + 1 wetroom	•	21	0.61	94
Kitchen + 2 wetrooms	•	29	0.57	94
Kitchen + 3 wetrooms	•	37	0.62	92
Kitchen + 4 wetrooms	•	45	0.7	92
Kitchen + 5 wetrooms	•	53	0.82	91
Kitchen + 6 wetrooms	•	61	0.98	90
Kitchen + 7 wetrooms	•	69	1.15	90

HRX2D PRODUCT CHARACTERISTICS DATABASE (SAP 2009)

	Thermal Bypass	Air Flow (l/s)	Specific Fan Power W/(l/s)	Heat Exchange Efficiency (%)
Kitchen + 1 wetroom	•	15	0.64	95
Kitchen + 2 wetrooms	•	21	0.56	94
Kitchen + 3 wetrooms	•	27	0.55	94
Kitchen + 4 wetrooms	•	33	0.59	93
Kitchen + 5 wetrooms	•	39	0.62	92
Kitchen + 6 wetrooms	•	45	0.67	92
Kitchen + 7 wetrooms	•	51	0.79	91

PERFORMANCE

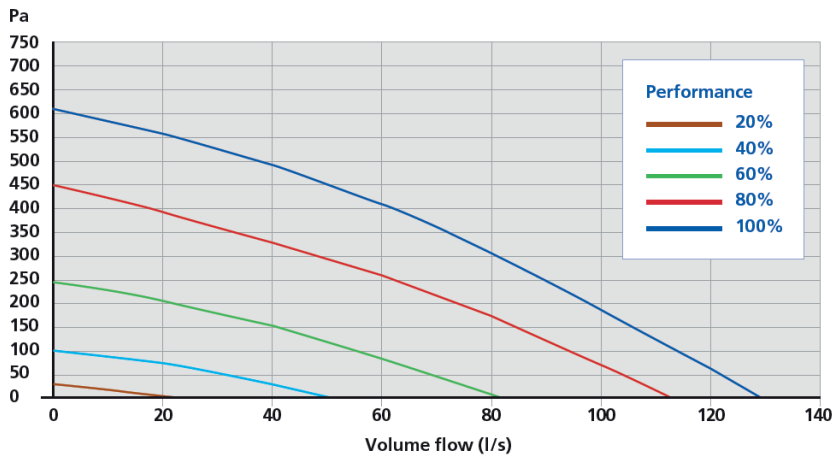

DIMENSIONAL DRAWING

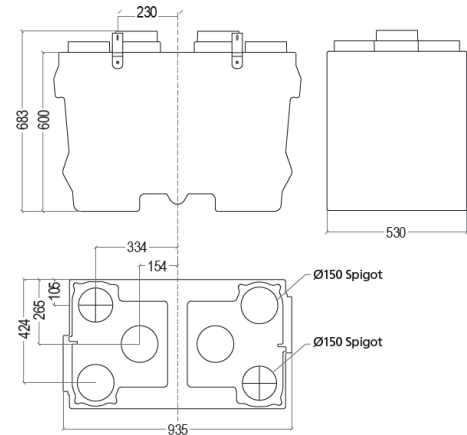

BREAKOUT SOUND PERFORMANCE

Speed Setting	Sound Power Levels dB re 1pW							Sound Pressure (dB(A) @ 3m)
	125	250	500	1000	2000	4000	8000	
25%	34	31	27	23	20	19	25	10
50%	45	43	40	36	30	20	25	21
75%	49	61	51	47	42	31	26	33
100%	53	62	58	54	50	41	30	39

INDUCT SUPPLY SOUND PERFORMANCE

Speed Setting	Sound Power Levels dB re 1pW						
	125	250	500	1000	2000	4000	8000
25%	49	42	38	28	22	20	26
50%	61	56	52	44	38	24	26
75%	65	68	63	56	51	39	31
100%	70	78	71	64	60	50	42

INDUCT EXTRACT SOUND PERFORMANCE

Speed Setting	Sound Power Levels dB re 1pW						
	125	250	500	1000	2000	4000	8000
50%	46	37	27	18	17	19	25
75%	53	49	38	28	22	20	25
100%	55	61	51	39	33	22	25
	59	68	55	48	41	31	27

ADVANCED CONTROL

Through advanced AMIE technology (Air Management for Indoor Environments), the Bluebrain controller not only offers simple pre-programmed functions, such as night time cooling and intelligent thermal bypass, it also allows for straightforward commissioning.

INTELLIGENTLY MANAGES AIR CONDITIONS

Digital humidity control aiding homeowner comfort

Through advanced AMIE technology, unlike typical humidity sensors, the Bluebrain HRX2D controller will enable occupants to have direct control over managing the humidity levels in their home - to suit personal comfort levels. By accurately measuring air humidity, the HRX2D's extract speed automatically changes from background to boost as the level of humidity increases, thereby providing optimal ventilation performance.

Advanced thermal bypass control

Perfect for night time cooling or during warmer periods, the HRX2D controller detects when the air temperature reaches a pre-set level and intelligently activates the thermal bypass mechanism to maximise the effect of maintaining fresh and filtered air.

The thermal bypass is also programmable by time, for additional convenience and comfort.

Incorporates Amie Technology

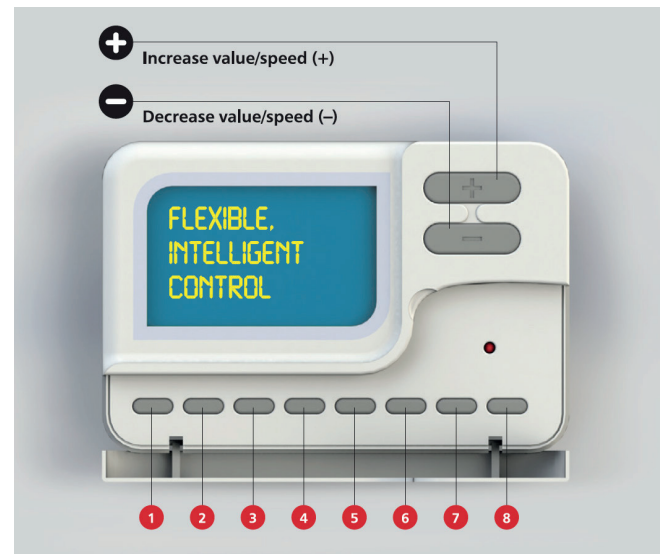

- 1 Set temperature activation point
- 2 Set date and time
- 3 Set humidity trigger point
- 4 Adjust thermal (summer) bypass
- 5 Copy program
- 6 Select and edit program
- 7 Escape function
- 8 Save function



ADVANCED CONTROL



Commissioning made easier

Engineered to include independent speed control, the Bluebrain control allows quick and accurate commissioning through simple speed adjustment buttons.



AMIE technology takes the hassle out of commissioning!

DIRTY FILTER INDICATOR

Automated filter maintenance and replacement reminders

Ease of maintenance and filter replacement is an important consideration when choosing MVHR – not only to ensure performance of the unit is maximised and air quality maintained, but also for peace of mind.

The HRX2D Bluebrain control removes this concern by providing helpful maintenance reminders for cleaning its filters.

BMS CAPABILITIES

Building Management Systems (BMS)

The HRX2D controller incorporates volt free contacts for fault and filter cleaning indication, to work with a Building Management System.

Summary of control functions

- ▶ Includes advanced AMIE technology (Air Management for Indoor Environments)
- ▶ Power indicator
- ▶ Status indicator (frost protection, thermal bypass, etc.)
- ▶ Fault indicator with diagnostics
- ▶ Independent fan speed control
- ▶ Switched live inputs (signal triggers):
 - Mains level x 2
 - Volt free to boost x 2
 - Volt free to max x 1
- ▶ 3 variable speeds
- ▶ Clean filter indicator
- ▶ Frost protection
- ▶ Built in humidistat
- ▶ Run on boost timer
- ▶ Delay 'on' boost
- ▶ Pre commissioning filter protection
- ▶ Discreet run monitor
- ▶ Lockable commissioning mode
- ▶ BMS features:
 - Pre heater activation output
 - Remote shutdown
 - System healthy monitor and fault signals
- ▶ Time and date display
- ▶ Real time air temperature display
- ▶ Real time extract air humidity level display
- ▶ Easy to read, contemporary digital display

**YOUR
VENTILATION
SPECIALIST**

03443 715 523

www.domusventilation.co.uk

domusventilation_



©Domus Ventilation 2022. Issue date 2022-08

The information contained in this publication is correct at the time of print and is subject to change. Please visit our website for the latest information: www.domusventilation.co.uk

Domus Ventilation | Block C, Van Court, Caerphilly CF83 3ED, United Kingdom