

Description for all types

- **Casing**
 Made of galvanised steel sheet, types HQ and HW have additional two layer lacquer coating in papyrus white. Explosion-proof types have no lacquer coating
- **Impeller**
 High performance characteristics with profiled blades made of plastic, dynamically balanced. Different for explosion-proof types.
- **Drive**
 Closed die-cast aluminium casing. Prot. cat. IP55. Ball bearing mounted. Maintenance-free and radio interference-free. Winding with moisture proof coating. See type table for max. air flow temperature. Different for explosion-proof types.

- **Motor protection**
 All types (except for explosion-proof, see page 180) are equipped with thermal contacts. These should be wired with the motor protection circuit breaker (see type table) for effective motor protection.
- **Electrical connection**
 Standard terminal box (IP55) on back of motor. Additionally on outside of duct for HRF types. Different for explosion-proof types.
- **Protection grille**
 Made of powder-coated steel for HQ and HW (HQ Ex galvanised). In accordance with DIN EN ISO 13857.
- **Power control**
 The voltage-controllable types are identified in the "Current consumption max. with control"

column with a value which must be observed when determining the controller (see speed controller column). Possible assignments of frequency inverters to fans are shown in the type table. The planned use of a frequency inverter without a sine filter should be indicated when placing the order. This requires a change of fan version and additional costs, if necessary. The flow rates are shown in the performance diagram.

- **Reverse operation**
 All types are reversible using a reverser switch. Performance reduction of approx. 1/3 in abnormal flow direction.
- **Installation**
 Installation possible in any position, but be aware of any condensate drain holes depending on usage.

■ **Dimensions**
 Pole-changeable and explosion-proof types may differ from the above information.

■ **Noise levels**
 See performance diagram. The sound power and sound pressure at 4 m distance under free field conditions are specified for the average operating point on the inlet/outlet side. See page 14 f for noise emissions and room acoustics. Different for expl.-proof types.

Reference	Page
Techn. description	180
Selection table	181
Planning information	14 ff.

Special design
 Different voltage, protection category, air flow direction, higher air flow temperature, acid protection and impeller made of cast aluminium upon request.

Speed min ⁻¹	Flow rate free-blowing V m ³ /h	Power consump. W	Current consump.		Wiring diagram No.	Max. air flow temp.		Weight net aprx. kg	Design type						
			at rated voltage A	max. with control A		at rated voltage + °C	with control + °C		HQ incl. protection grille	Ref. no.	HW incl. protection grille	Ref. no.	HRF	Ref. no.	Dim. B Motor protrusion in mm
Single-phase alternating current, 230 Volt, 50 Hz, Capacitor motor, protection category IP55															
935	5500	233	1.05	1.25	475 ¹⁾	60	40	19.0	HQW 500/6	01112	—	—	HRFW 500/6 ¹⁾	00210	—
1375	8320	1100*	5.90*	4.94	475 ¹⁾	40	40	25.0	HQW 500/4	01113	—	—	HRFW 500/4 ¹⁾	00211	60
Three-phase current, 400 Volt, 50 Hz, Squirrel-cage rotor, protection category IP55															
920	5480	218	0.48	0.55	469	60	40	19.0	HQD 500/6	01126	—	—	HRFD 500/6	00232	—
1345	8200	620	1.22	1.32	469	40	40	19.5	HQD 500/4	01127	HWD 500/4	01030	HRFD 500/4	00233	—
Two-speed, three-phase current, 400 V, 50 Hz, Y/Δ connection, protection category IP55															
615/920	4330/5450	133/214	0.29/0.46	—	520	60	—	18.0	HQD 500/6/6	01471	—	—	—	—	—
1030/1350	6720/8150	416/617	0.76/1.19	—	520	60	—	24.0	HQD 500/4/4	01469	—	—	HRFD 500/4/4	01470	120
2450/2830	13615/12050	1960/2470*	3.14/4.73*	—	520	40	—	30.0	—	—	—	—	HRFD 500/2/2	00485	150
Pole-changeable, 2 speeds, three-phase current, Dahlander winding, 400 Volt, 50 Hz, protection category IP55															
465/940	2680/5490	71/248	0.23/0.56	—	472	60	—	18.0	HQD 500/12/6	01140	—	—	—	—	—
700/1385	3890/8280	137/688	0.52/1.48	—	472	40	—	22.0	HQD 500/8/4	01142	—	—	HRFD 500/8/4	00407	—
Ex Ex Explosion-proof, II 2G Ex h IIB + H₂ T3 Gb, Motor Ex e, three-phase current 400 Volt, 50 Hz, protection category IP55															
920	5610	250*	0.97*	—	470	40	—	18.0	HQD 500/6 Ex	01050	—	—	HRFD 500/6 Ex	00489	10
1390	8560	750*	2.00*	—	470	40	—	18.0	HQD 500/4 Ex	01157	—	—	HRFD 500/4 Ex	00483	45

* Motor ratings, Ex see information on page 20. ¹⁾ Type HRFW: Connection according to wiring diagram no. 965. ²⁾ Incl. motor protection circuit breaker. ³⁾ Incl. speed pole changing switch.

Performance curves 500/2

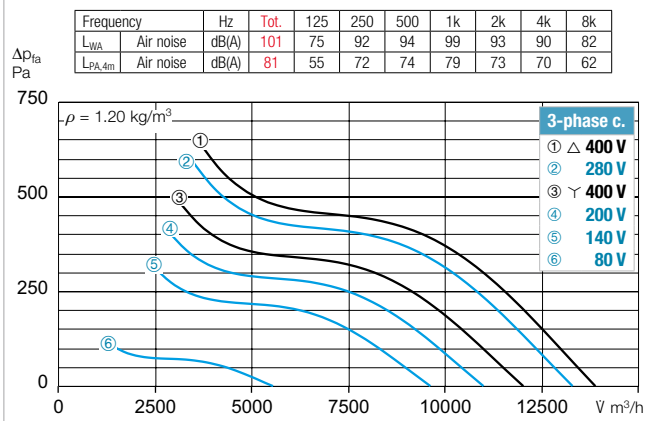

Performance curves 500/4

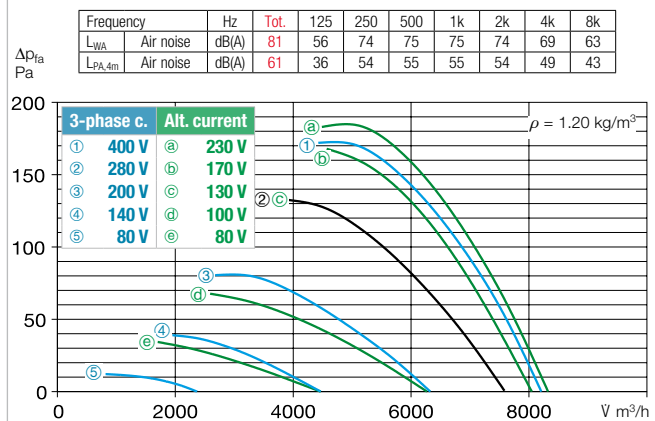

Performance curves 500/6

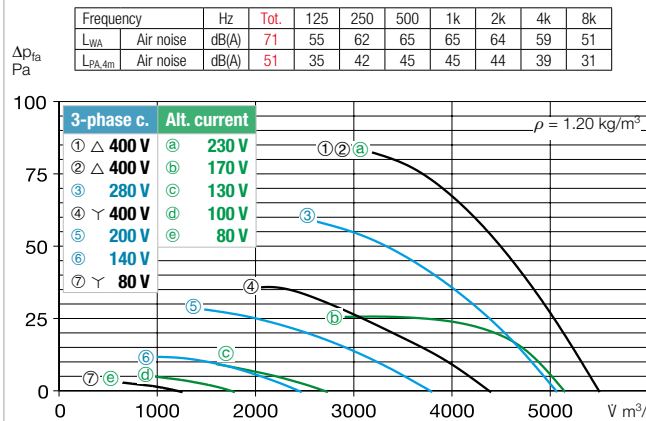

Performance curve 500/8

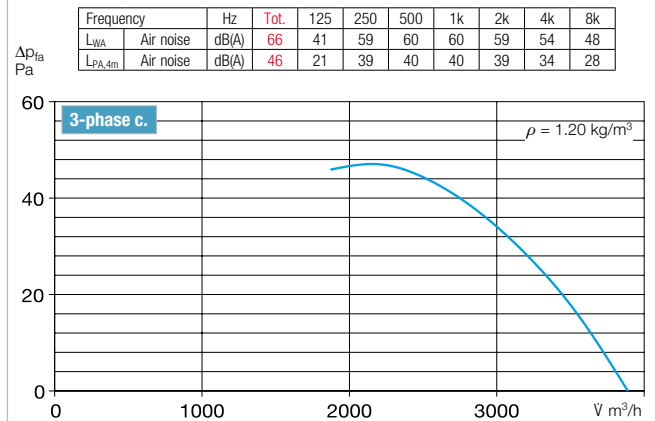

Accessories for HRF 500 Description see page 276 ff.

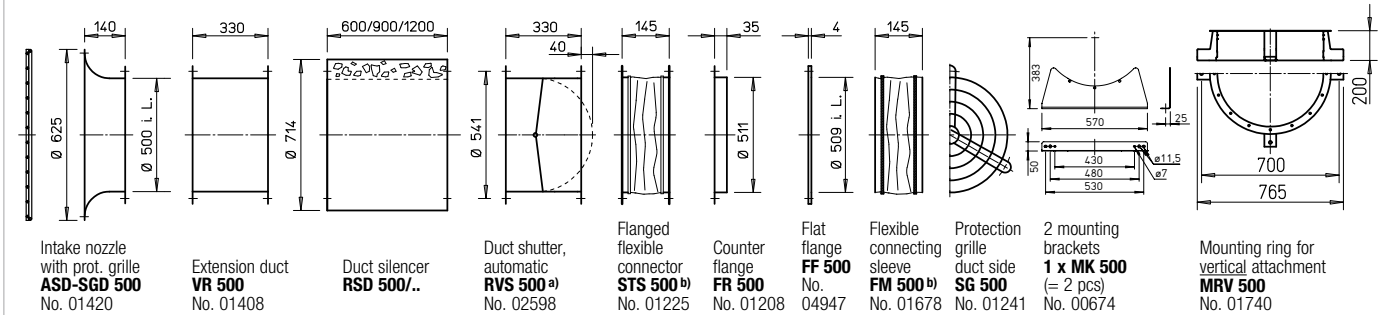

a) Shutter, motorised see Accessories product pages.

b) See below for types for explosion-proof fans.

Frequency inverter with integrated sine filter	Transformer speed controller 5-step, pole changing switch	Electronic speed controller, continuously variable flush-m./surface-m.	Motor protection circuit breaker for connecting built-in thermal contacts	Reverser switch					
Type	Ref. no.	Type	Ref. no.	Type	Ref. no.				
—	MWS 1.5 ²⁾	01947	ESU 3/ESA 3	00237/00239	MW	01579	WS	01271	
—	MWS 5 ²⁾	01949	ESU 5/ESA 5	01296/01299	MW	01579	WS	01271	
FU-BS 2.5 ²⁾	05459	RDS 1 ²⁾	01314	ESD 5 ²⁾	00501	MD	05849	WS	01271
FU-BS 2.5 ²⁾	05459	RDS 2 ²⁾	01315	ESD 5 ²⁾	00501	MD	05849	WS	01271
Speed changeover switch									
FU-BS 2.5 ²⁾	05459	DS 2 ⁵⁾	01351	—	—	M 4 ⁴⁾ /MD	01571/05849	WS	01271
FU-BS 2.5 ²⁾	05459	DS 2 ⁵⁾	01351	ESD 5 ²⁾	00501	M 4 ⁴⁾ /MD	01571/05849	WS	01271
FU-BS 5.0 ²⁾	05460	RDS 7 ²⁾	01578	ESD 11.5 ²⁾	00502	M 4 ⁴⁾ /MD	01571/05849	WS	01271
Pole changing switch									
—	PDA 12 ⁴⁾	05081	—	—	—	M 3 ³⁾	01293	PWDA	01282
—	PDA 12 ⁴⁾	05081	—	—	—	M 3 ³⁾	01293	PWDA	01282
—	not permitted	—	not permitted	—	—	—	—	—	—
—	not permitted	—	not permitted	—	—	—	—	—	—

4) Flush-m. version see Switch product page. 5) Speed changeover switch.

Other accessories Page

- Access. for expl.-proof fans
- Flanged flexible connector STS 500 Ex Ref. no. 02507
- Flexible connecting sleeve FM 500 Ex Ref. no. 01694
- Extension sleeve for HS VH 500 Ref. no. 01348
- Cylindrical pipe section, galvanised steel, 15 cm long.
- Filter and silencers 481 ff.
- Shutters and ventilation grilles 561 ff.
- Speed controllers, controllers and switches 599 ff.