



AirPal

Stronger than any virus: Helios air purifier AirPal.



Healthiness for your



Patients



Employees



Clients



Visitors



Students

Economic security for you.



Hot topic: healthy air.

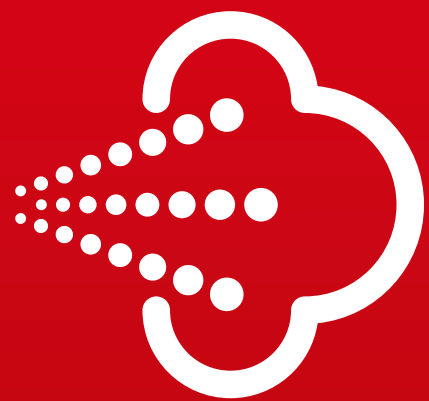

Whether at work, at school or during leisure activities – large areas of our lives take place in enclosed spaces. Wherever people are present in large numbers, there is a fundamental risk that pathogenic germs are transmitted from an infected person to other persons. Immediate measures such as distancing rules and regular surface disinfection are effective measures for mitigating the risk of infections from droplets or contact surfaces. However, experience from recent months has primarily shown that aerosols are carriers of dangerous viruses, which makes it necessary to implement further

preventive measures. Aerosols (minute airborne particles of solid and liquid substances) circulate quickly and with hardly any restriction in enclosed spaces, unlike heavy droplets. Only when it is ensured that areas occupied by potentially infected people are continuously and sufficiently supplied with unpolluted air can the room aerosol concentration be reduced to an uncritical level.

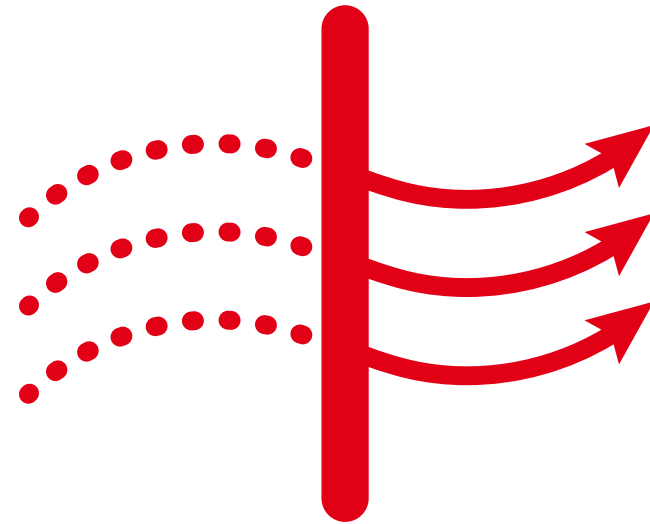

Proper ventilation. Easier said than done.

The most effective preventive measures against viral infection include very clear recommendations on safe ventilation. Accordingly, all windows in the room should be opened for a few minutes for sufficient air exchange – at least once per hour. This process should take place every 20 minutes in conference rooms and classrooms. In addition, it is recommended to permanently leave the windows in the tilted position. This is hardly feasible in reality and leads to numerous negative side effects

- Draughts, noise disturbance and negative environmental impacts such as dust, exhaust fumes and pollen become unavoidable.
- Colds and infections due to the cold outside air are inevitable, especially in winter.
- The lower indoor humidity affects the mucous membranes and increases the risk of infection. The lifespan of viruses and bacteria also increases in the air.
- Rooms often do not have enough windows that are large enough to ensure the air exchange.

Our formula against viruses.

AirPal air purifiers from Helios are a reliable way to efficiently remove the aerosols identified as carriers of Covid-19 viruses from the room air. They are immediately operational, they do not require installation or adjustment and they are therefore an immediate measure for quickly ensuring safety in indoor spaces without red tape. Of course, AirPal are equipped with all the features that you can expect from a leading ventilation specialist. The units not only operate quietly in an energy saving manner, but they are also extremely robust and designed for continuous operation.

In order to provide the ideal solution for each of your areas of application, AirPal are available in various sizes and designs as floor-standing units for e.g. class rooms, restaurants and waiting rooms as well as rollable mobile units for flexible use in different meeting rooms depending on usage.

99.995 % fewer viruses with AirPal.

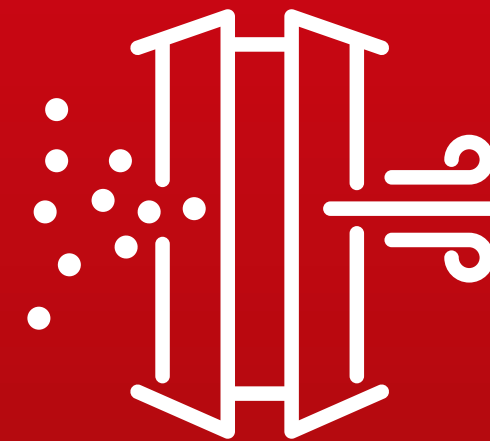

* AirPal air purifier series H are equipped with filters of the highest quality grade HEPA 14 and they demonstrably filter 99.995 % of all viruses from the room air. AirPal units in series U safely and reliably eliminate viruses via UV-C disinfection.

Helios offers you the widest range of air purifiers.



AirPal

This series includes four floor-standing units with two forms of purification technology for stationary use.

- Available in performance classes 300 – 2.200 m³/h. For room sizes up to 180 m²*.
- AirPal with three level filter concept incl. HEPA 14 remove 99.995 % of all viruses from the room air.
- AirPal with UV-C disinfection system effectively and safely eliminates viruses.

*with quadruple air exchange and maximum flow rate.

AirPal Go

This mobile series consists of four units for flexible deployment.

- Available in performance classes 100 – 850 m³/h. For room sizes up to 70 m²*.
- With multi-level HEPA 14 filter concept for the elimination of 99.995 % of all viruses.

Highlights:



Technology for a breath of fresh air.

AirPal air purifiers are equipped with a highly efficient filter concept with up to three levels. In addition to their outstanding virus protection, they also filter harmful substances and fine particles from the room air.



Unpack and get started.

Helios AirPal is delivered pre-configured – all you need is one free power socket and you can breathe with confidence.



Helios AirPal is green.

The latest EC fans ensure that the air purifiers not only operate reliably, but also in an energy saving manner.



Enjoy the peace and quiet.

AirPal impresses with an innovative sound insulation concept with quiet operation, so you will not be disturbed.





AirPal

Helios

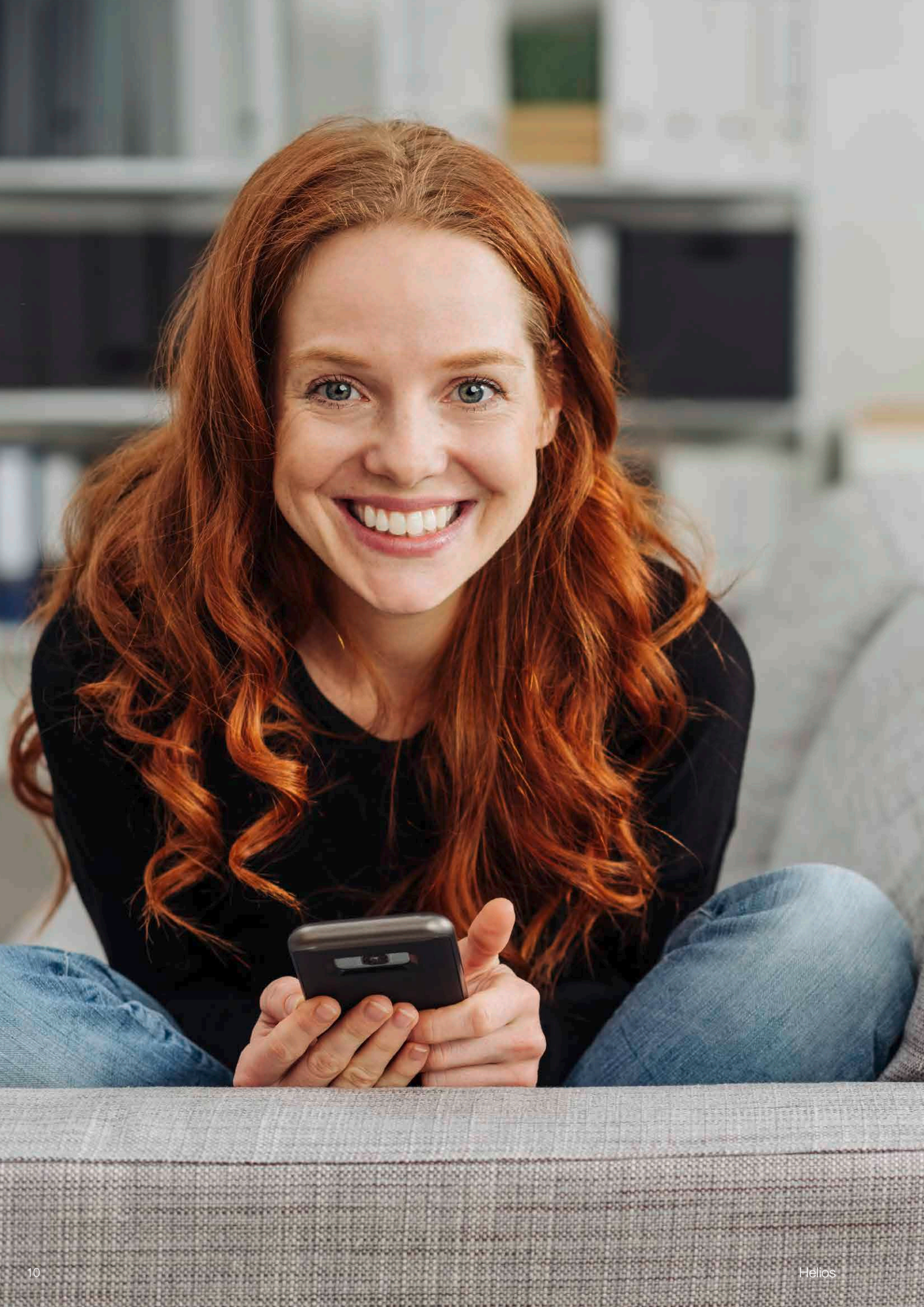

The easy way to healthy air.

> **Before ordering:** Find the optimal unit for your application now. We will assist you with a German selection tool at www.AirPalSelect.com

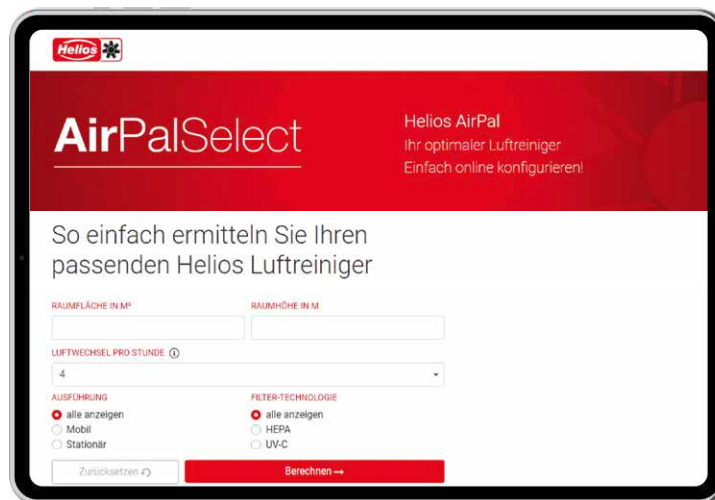

The screenshot shows the Helios AirPalSelect website interface. At the top left is the Helios logo. The main heading is 'AirPalSelect' with the tagline 'Helios AirPal Ihr optimaler Luftreiniger Einfach online konfigurieren!'. Below this, a sub-heading reads 'So einfach ermitteln Sie Ihren passenden Helios Luftreiniger'. The form contains several input fields: 'RAUMFLÄCHE IN M²' and 'RAUMHÖHE IN M' are empty text boxes; 'LUFTWECHSEL PRO STUNDE' is a dropdown menu currently set to '4'; 'AUSFÜHRUNG' has radio buttons for 'alle anzeigen', 'Mobil', and 'Stationär', with 'alle anzeigen' selected; 'FILTER-TECHNOLOGIE' has radio buttons for 'alle anzeigen', 'HEPA', and 'UV-C', with 'alle anzeigen' selected. At the bottom are two buttons: 'Zurücksetzen' and 'Berechnen'.

> **Delivery:** Helios AirPal is delivered **preconfigured and ready to plug in**. Simply plug into a power socket and AirPal will immediately start to improve the room air.

> **In everyday life:** Almost all AirPal air purifiers can be variably controlled. You can also easily determine the optimal controller position for your application at www.AirPalSelect.com – automatic, safe and fast.

> **In the future:** You will not require tools for the filter replacement – you can find all replacement filters at www.ersatzluftfilter.de and these can be easily replaced.



Helios AirPal:
perfect for all
areas of application.

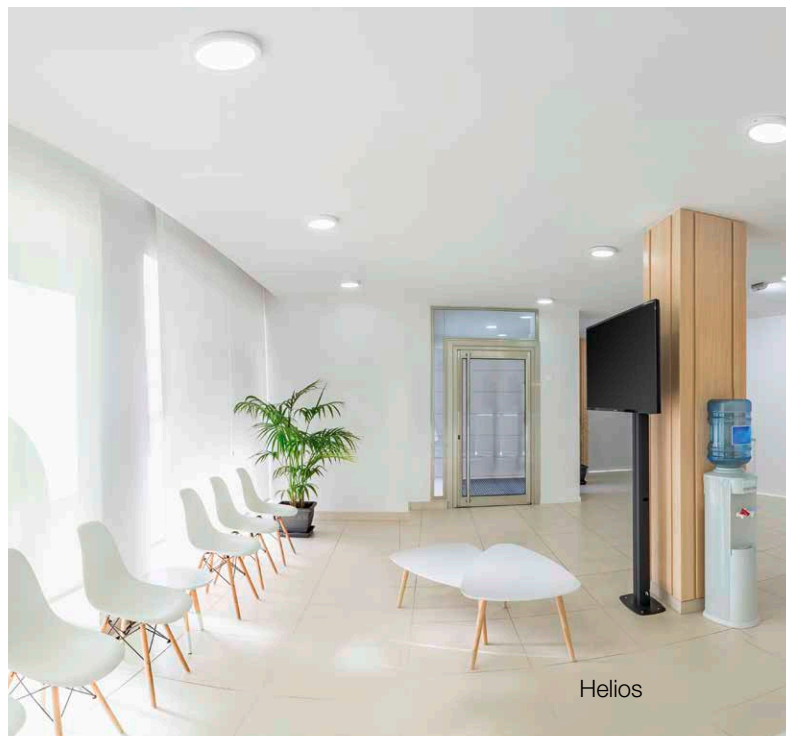
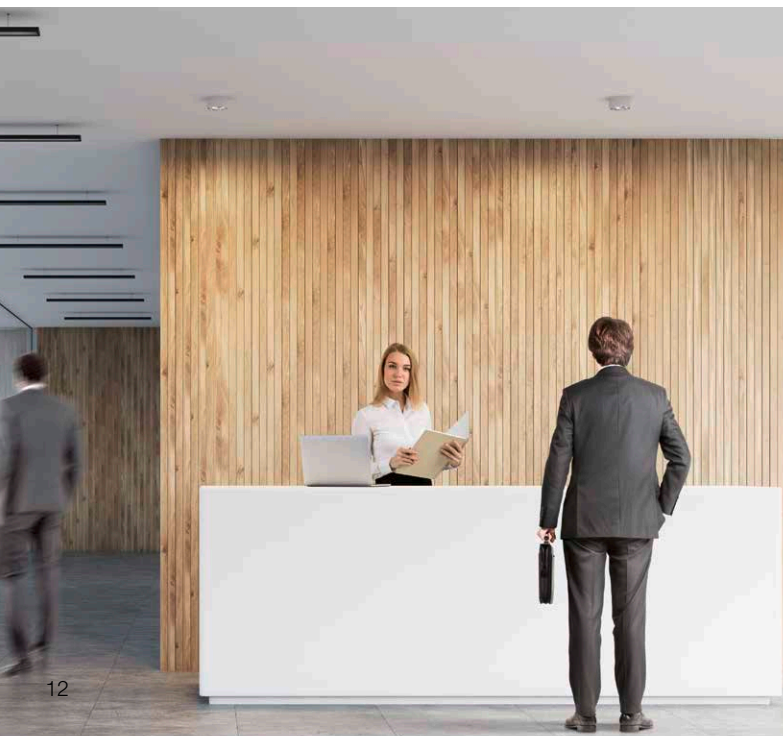
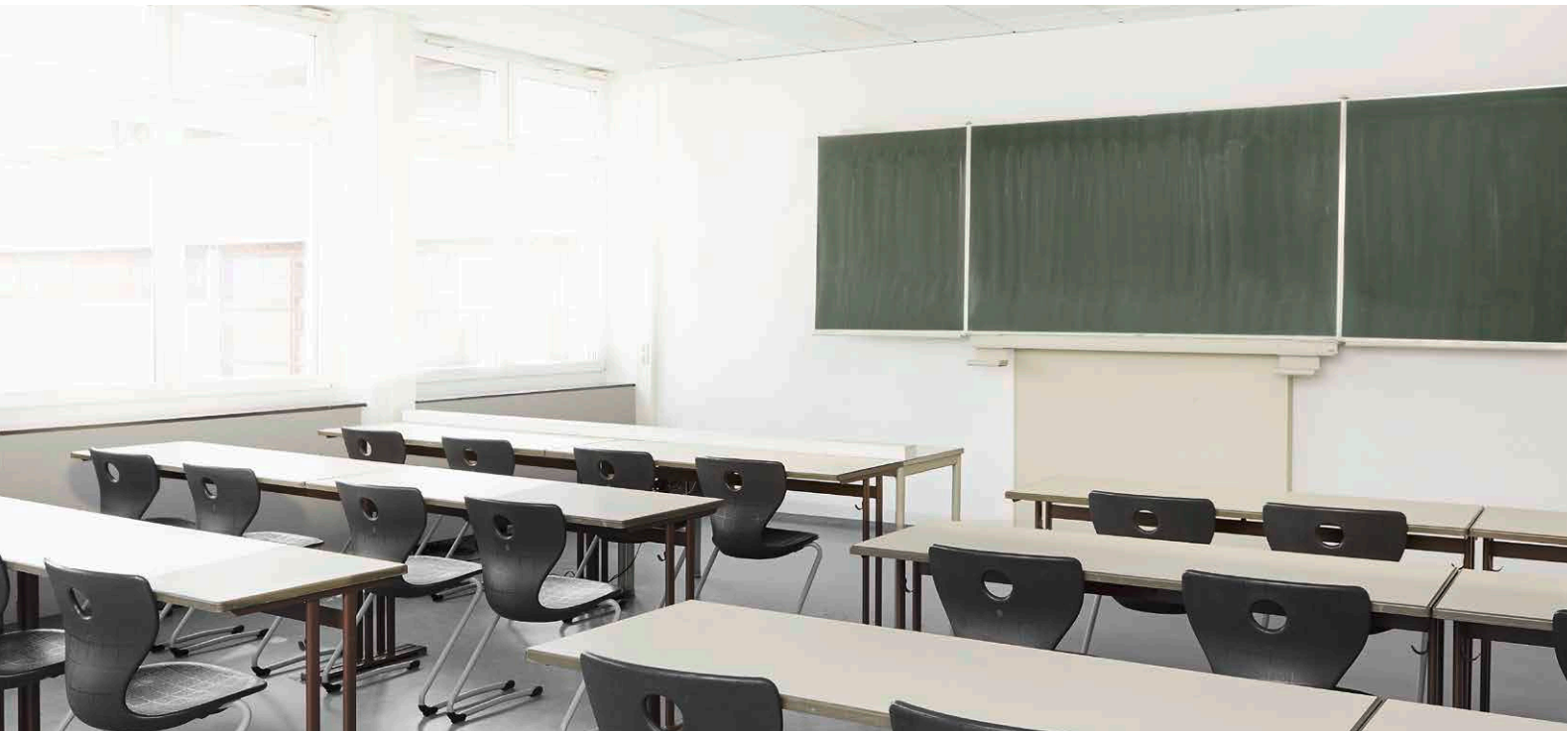



- Schools and universities
- Kindergartens
- Waiting rooms and doctor's offices
- Salesrooms
- Hotels
- Offices and meeting rooms
- Nursing facilities
- Restaurants
- Sports facilities
- ... and much more!



AirPal

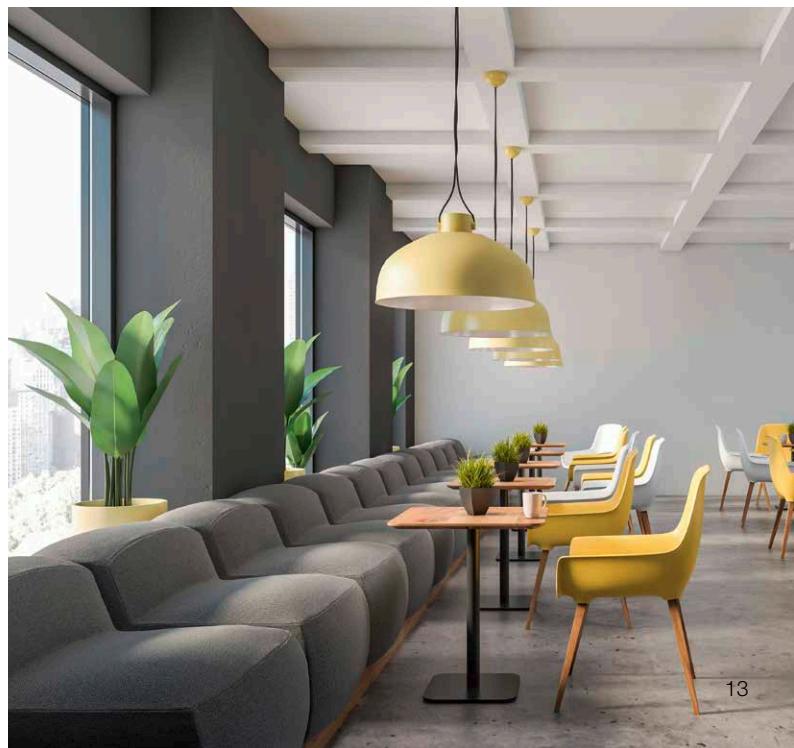

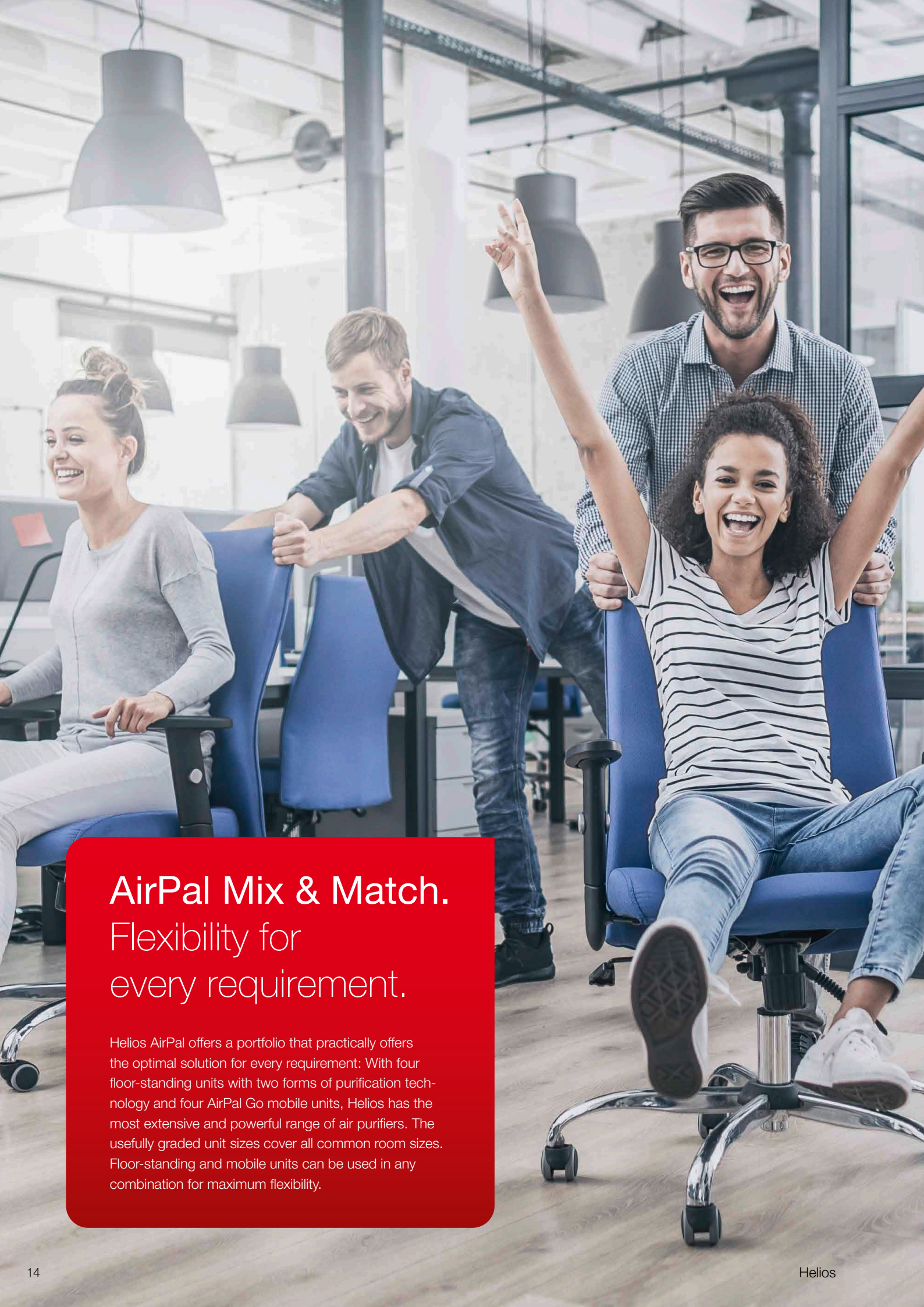

AirPal Mix & Match. Flexibility for every requirement.

Helios AirPal offers a portfolio that practically offers the optimal solution for every requirement: With four floor-standing units with two forms of purification technology and four AirPal Go mobile units, Helios has the most extensive and powerful range of air purifiers. The usefully graded unit sizes cover all common room sizes. Floor-standing and mobile units can be used in any combination for maximum flexibility.

Overview AirPal & AirPal Go.

■ Types		■ Selection criteria				■ Page
		Technology	V max (m³/h)	Suitable for room sizes up to*	Control	Further information
	AirPal 1750 H Ref. no: 00665	HEPA 14	1,750	146 m²	variable	18
	AirPal 2200 H Ref. no: 00663	HEPA 14	2,200	183 m²	variable	18
	AirPal 900 U Ref. no: 00670	UV-C	900	75 m²	automatic (constant volume)	19
	AirPal 1200 U Ref. no: 00669	UV-C	1,200	100 m²	automatic (constant volume)	19
	AirPal Go 650 H Ref. no: 00673	HEPA 14	650	54 m²	variable	22
	AirPal Go 850 H Ref. no: 00671	HEPA 14	850	71 m²	variable	22
	AirPal Go 300 H Ref. no: 00661	HEPA 14	300	25 m²	variable	23
	AirPal Go 600 H Ref. no: 00662	HEPA 14	600	50 m²	variable	23

*with quadruple air exchange and maximum flow rate.

Two technologies – One mission. Helios AirPal floor-standing units.

HEART OF THE SYSTEM: HEPA 14 OR UV-C

With four floor-standing units with two forms of purification technology, Helios offers the right solution for a wide range of operating locations and room sizes. The **HEPA version AirPal H** are equipped with a 3 level filter concept. Following the two pre-filters of quality grades ePM10 70 % and ePM1 80 %, the HEPA high-performance filter (H14) meets the highest safety level with a separation efficiency of more than 99.995 %. Fine particles, aerosols, viruses and other microorganisms are reliably filtered out. The continuous monitoring of actual filter performance also guarantees flawless operation at all times.

The **UV-C version AirPal U floor-standing units** are equally impressive: In addition to the UV-C technology protection, the majority of viruses, harmful substances and other particles are filtered from the air thanks to the multi-level pre-filtering. The subsequent UV-C disinfection eliminates the remaining viruses in a shielded section. The highlight: The units operate fully automatically in the optimal performance range. In this respect, they are designed for a duration of 9,000 operating hours before the lamp has to be replaced. The UV-C unit has multiple safeguards for the maximum protection of users and maintenance personnel.



Full power with efficiency

All AirPal units are equipped with powerful fans which are powered by advanced EC motor technology. This not only reduces energy consumption, but it also has a positive effect on noise emission.

The fans also show their full performance potential in combination with the optimised air flow concept. This results in excellent flow rates of up to 2,200 m³/h with the variably controllable units in series AirPal H. The AirPal U series units go one step further with fully automatic, optimal operation and thus they guarantee a constant flow rate at all times.



Air distribution without any draughts

With AirPal, the air flows into the room well above head height – this completely prevents draughts for the people in the room and ensures optimal air distribution in the room at all times.

Optimal acoustic properties

AirPal impresses with quiet operation so you are not disturbed at work. This is ensured by an elaborate sound insulation concept with an acoustically optimised casing. AirPal units in series H also have integrated silencers on the air inlets and outlets.

Robust and designed for continuous operation

AirPal air purifiers have been developed according to the highest quality and safety standards. The double-walled, sound-insulated casing design is extremely robust and easy to clean when necessary. All components used are low-maintenance and designed for continuous operation.

AirPal 1750 H / AirPal 2200 H



Dimensions AirPal 1750 H / AirPal 2200 H

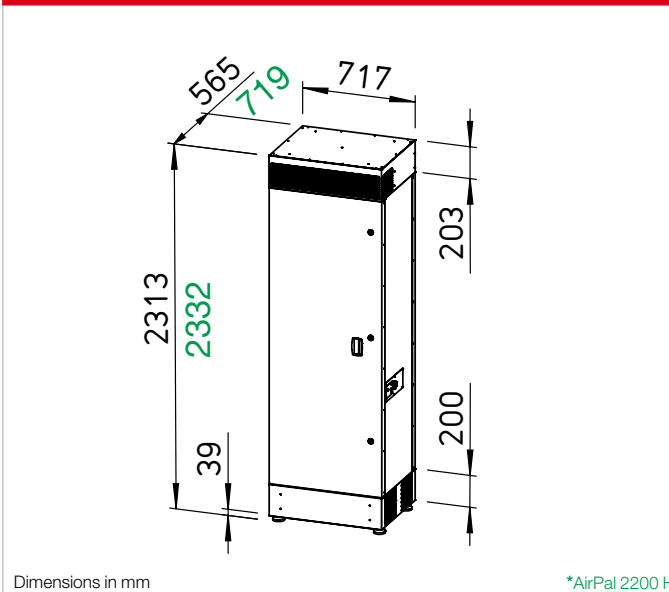

Compact floor-standing unit with air circulation for air purification in individual rooms up to approx. 180m². Equipped with a 3-level filter concept incl. HEPA 14 filter, 99.995 % of all viruses are removed from the room air. Ideal for rooms where many people are present, e.g. in class rooms, restaurants, waiting rooms, etc.

Highlights

- Stationary air purifier with Hepa 14 filter technology.
- Three-level filter concept incl. ISO ePM10 70 % pre-filter, ISO ePM1 80 % fine filter and Hepa14 high-performance filter.
- Variable output adjustment – individually as needed.
- Permanent filter monitoring incl. filter replacement indication.

Filter concept and efficiency

3-level filter concept with a course filter, fine filter and an efficient Hepa14 high-performance filter. The course and fine filters ensure the safe separation of larger particles, so that the Hepa14 filter is not contaminated and the service life is prolonged. The Hepa14 filter ensures the separation of 99.995 % of the particles in the 0.3 µm range.

Plug & Play

The units are delivered ready to plug in and they only require plugging in to a power socket.

Air exchange

Air purifiers must be designed on condition that sufficient air exchange is ensured. This depends on room size, number of persons, occupancy duration and activity level. Further information on ideal air exchange can be found at AirPalSelect.com.

Acoustics

Extremely quiet operation is ensured by the integrated silencers in the air outlet and casing, as well as the sound-optimised air flow and arrangement of internal components.

Air inlet/outlet

The base-side arrangement of the air inlet and the top-side arrangement of the air outlet ensure optimised air circulation in the room, so that the required air exchange is guaranteed. This effectively prevents draughts.

Power control

The output is variably adjusted to personal needs up to 100 %. All three filters are individually pressure-monitored. Warning LEDs indicate dirty filters and necessary replacement.

Installation

The units are designed for wall installation in rooms. They are mounted to the wall using the integrated locking device.

Fans

Low-noise EC high-performance fan with backward-curved impeller ensures maximum energy efficiency.

Replacement air filter (unit = 1 pc)

For AirPal 1750 H:

- ELF-AirPal 1750+900/ePM10 70% Ref. no. 40135
- ELF-AirPal 1750+900/ePM1 80% Ref. no. 40136
- ELF-AirPal 1750 H/Hepa 14 Ref. no. 40137

For AirPal 2200 H:

- ELF-AirPal 2200+1200/ePM10 70% Ref. no. 40138
- ELF-AirPal 2200+1200/ePM1 80% Ref. no. 40139
- ELF-AirPal 2200 H/Hepa 14 Ref. no. 40140

Technical data				
Unit	AirPal 1750 H	Ref. no. 00665	AirPal 2200 H	Ref. no. 00663
Output				
V m³/h min.		300		370
V m³/h with V = 50 %		850		1100
V m³/h max.		1750		2200
Maximum recommended room size				
Area m² (with V max (quadruple air exchange))		146		183
Sound power level				
LwA dB(A) (with V min.)		30		31
LwA dB(A) (with V = 50 %)		52		52
LwA dB(A) (with V max.)		65		68
Sound pressure level at 1m				
LpA dB(A) (with V min.)		22		23
LpA dB(A) (with V = 50 %)		44		44
LpA dB(A) (with V max.)		57		60
Power consumption				
W (with V min.)		11		18
W (with V = 50 %)		71		63
W (with V max.)		494		473
Filter concept		3-level / HEPA		3-level / HEPA
Course filter		ISO ePM10 70% (M6)		ISO ePM10 70% (M6)
Fine filter		ISO ePM1 80% (F9)		ISO ePM1 80% (F9)
High-performance filter		H14		H14
Rated current A		2.5		2.5
Voltage/frequency		230 V~, 50/60 Hz		230 V~, 50/60 Hz
Protection category IP		20		20
Weight in kg		150		185

AirPal 900 U / AirPal 1200 U



Dimensions AirPal 900 U / AirPal 1200 U

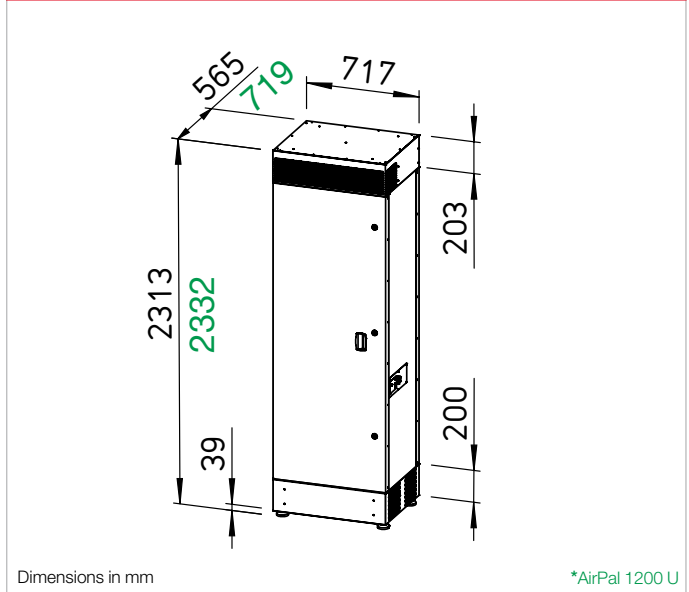

Compact floor-standing unit with air circulation for air purification with UV-C disinfection for the complete elimination of viruses. Ideal for rooms where many people are present, e.g. in offices, restaurants, waiting rooms, etc.

■ Highlights

- Viruses are effectively and safely eliminated in a separate section through UV-C disinfection.
- Constant volume control also ensures the correct air volume and UV-C dose even when filters are dirty.
- Permanent filter monitoring incl. filter replacement indication.

■ Filter concept and efficiency

2-level filter concept with a course and fine filter. These separate a large number of particles and

viruses, protect the UV-C lamps against contamination and ensure the UV-C dose and effectiveness of the lamps.

■ Safety

In order to protect against potentially harmful radiation, the lamps are located in a separate section. This prevents UV-C leakage. The UV-C light is switched off during maintenance work by means of door contacts.

■ UV-C dose / sterilisation rate

The DNA of bacteria and viruses is damaged and rendered ineffective by UV-C disinfection. The effect depends largely on the UV-C dose. For example, a dose of 3.6 mJ/cm² is required for the influenza virus to eliminate 90 % of the viruses. With regard to corona viruses, it is currently assumed that around

4 mJ/cm² is sufficient to eliminate more than 90 % of the viruses. AirPal series U have a dose of 8.3 mJ/cm² and can therefore eliminate more than 99 % of corona viruses.

■ Plug & Play

The units are delivered ready to plug in and they only require plugging in to a power socket.

■ Air exchange

Air purifiers must be designed on condition that sufficient air exchange is ensured. This depends on room size, number of persons, occupancy duration and activity level (at least quadruple air exchange). Further information on ideal air exchange can be found at AirPalSelect.com.

■ Acoustics

Quiet operation is ensured by

the integrated silencers in the air outlet and casing, as well as the sound-optimised air flow and arrangement of internal components.

■ Air inlet/outlet

The base-side arrangement of the air inlet and the top-side arrangement of the air outlet ensure optimised air circulation in the room, so that the required air exchange is guaranteed. This effectively prevents draughts.

■ Power control

The constant volume control also ensures a constant air volume and the correct UV-C dose even when the filters are dirty. A lower level can also be set if necessary. Both filters are individually pressure-monitored. LEDs indicate any necessary filter or UV-C lamp replacement.

■ Installation

The units are designed for wall installation in rooms. They are mounted to the wall using the integrated locking device.

■ Fans

Low-noise EC high-performance fan with backward-curved impeller ensures maximum energy efficiency.

■ Replacement air filter (unit = 1pc)

For AirPal 900 U:

- ELF-AirPal 1750+900/ePM10 70%**
Ref. no. 40135
- ELF-AirPal 1750+900/ePM1 80%**
Ref. no. 40136

For AirPal 1200 U:

- ELF-AirPal 2200+1200/ePM10 70%**
Ref. no. 40138
- ELF-AirPal 2200+1200/ePM1 80%**
Ref. no. 40139

Technical data				
Unit	AirPal 900 U	Ref. no. 00670	AirPal 1200 U	Ref. no. 00669
Output				
∇ m³/h reduced		600		900
∇ m³/h optimal		900		1200
Maximum recommended room size				
Area m² (with ∇ max (quadruple air exchange))		75		100
Sound power level				
LwA dB(A) (with ∇ reduced)		48		48
LwA dB(A) (with ∇ optimal)		53		53
Sound pressure level at 1m				
LpA dB(A) (with ∇ reduced)		40		40
LpA dB(A) (with ∇ optimal)		45		45
Power consumption				
W (with ∇ reduced)		320		465
W (with ∇ optimal)		380		495
Filter concept		2-level / UV-C		2-level / UV-C
Course filter		ISO ePM10 70% (M6)		ISO ePM10 70% (M6)
Fine filter		ISO ePM1 80% (F9)		ISO ePM1 80% (F9)
UV-C disinfection				
UV-C dose mJ/cm²		7,9		8
UV-C wavelength nm		253.7		253.7
Rated current A		1,8		2,3
Voltage/frequency		230 V~, 50/60 Hz		230 V~, 50/60 Hz
Protection category IP		20		20
Weight in kg		140		170

Safety to go. Helios AirPal Go mobile units.

Strong and robust

AirPal Go air purifiers are designed for flexible application and changing locations – e.g. in schools, businesses or restaurants.

Count on AirPal Go – 99.995 %

AirPal Go operate according to the principle of multi-level air filtration. Harmful substances and other particles are removed from the air in the first filter level and these are optimally processed in the next step. In this respect, a high-performance filter of the highest quality grade HEPA 14 ensures that 99.995 % of viruses are reliably removed!

AirPal Go works effortlessly – and variably

The built-in fans in AirPal Go operate with the latest EC technology for maximum power. This not only has positive effects on acoustics and energy consumption, but it also allows variable control.





AirPal Go air purifiers are unbeatably versatile and rapidly deployable wherever they are needed. This is ensured by plug-in operation, compact unit dimensions and the standard rollers. AirPal Go is therefore the first choice for installation locations where maximum application flexibility is required.

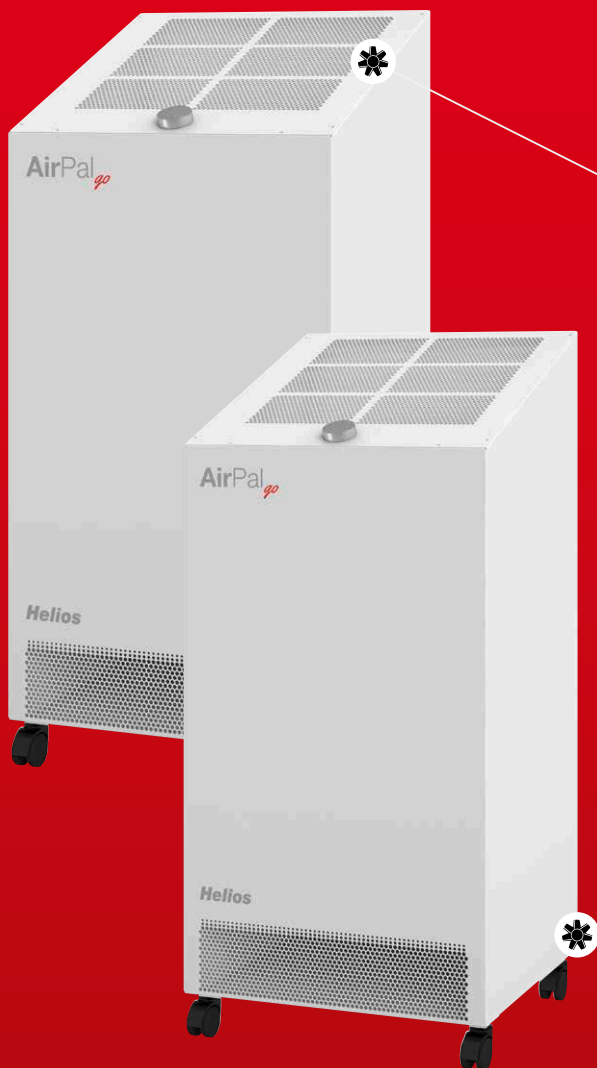

Do not be disturbed

From the EC fans to the casing: everything in AirPal Go has been developed and designed with a view to impressively quiet operation. The air outlets in AirPal Go 650 H and 850 H have been designed in such a way that the air flowing into the room is distributed upwards. AirPal Go 300 H and 600 H draw air in at the side and blow it out downwards.

Healthy air on rollers

Lightweight, compact and ultra-mobile: Use AirPal Go flexibly where you need it. Floor-standing and mobile units can easily be combined with AirPal Mix & Match and thus peaks in demand during e.g. large conferences can be equalised in no time.

AirPal Go 650 H / AirPal Go 850 H



Dimensions AirPal Go 650 H / AirPal Go 850 H

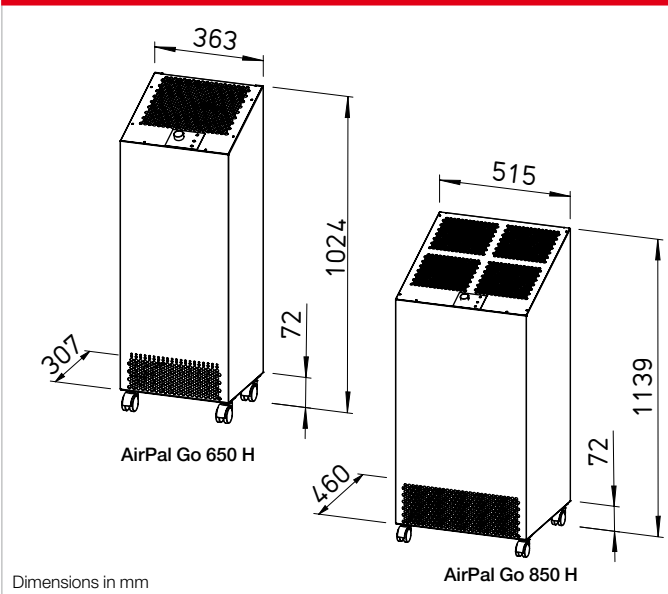

Mobile unit with air circulation for air purification of smaller individual rooms up to 70 m². Multiple units can be combined in larger rooms. Equipped with a 2-level filter concept incl. HEPA 14, 99.995 % of all viruses are removed from the room air.

■ Highlights

- Mobile air purifier with Hepa 14 filter technology.
- Two level filter concept incl. ePM10 70 % pre-filter and Hepa high-performance filter.
- 99.995 % of all viruses are filtered out of the air.
- Variable output adjustment – individually as needed.
- Permanent filter-monitoring incl.

filter replacement indication

■ Filter concept and efficiency

The 2 level filter concept consists of a pre-filter and an efficient Hepa14 high-performance filter. The pre-filter ensures the safe separation of larger particles, so that the Hepa14 filter is not contaminated and the service life is prolonged. the Hepa14 filter ensures the separation of 99.995 % of particles in the 0.3 µm range.

■ Plug & Play

The units are delivered ready to plug in and they only require plugging in to a power socket.

■ Air exchange

Air purifiers must be designed on condition that sufficient air exchange is ensured. This depends on room size, number of persons, occupancy duration and activity level. We recommend at least quadruple air exchange. Further information on ideal air exchange can be found at AirPalSelect.com.

■ Acoustics

Quiet operation is ensured by an efficiently designed fan as well as the sound-optimised air flow and arrangement of internal components.

■ Air inlet/outlet

The base-side arrangement of the

air inlet and the top-side arrangement of the air outlet ensure optimised air circulation in the room, so that the required air exchange is guaranteed.

■ Power control

The output is variably adjusted to personal needs. Both filters are individually pressure-monitored. Warning LEDs indicate dirty filters and necessary replacement.

■ Installation

The units are mobile and can be flexibly positioned due to the wheels.

■ Fans

Low-noise EC high-performance fan with backward-curved impeller ensures maximum energy efficiency.

■ Replacement air filter (unit = 1 pc)

- For AirPal Go 650 H:
ELF-AirPal Go 650 H/ePM10 70%
 Ref. no. 40141
ELF-AirPal Go 650 H/Hepa 14
 Ref. no. 40142

- For AirPal Go 850 H:
ELF-AirPal Go 850 H/ePM10 70%
 Ref. no. 40143
ELF-AirPal Go 850 H/Hepa 14
 Ref. no. 40144

Technical data				
Unit	AirPal Go 650 H	Ref. no. 00673	AirPal Go 850 H	Ref. no. 00671
Output				
V m ³ /h min.		100		150
V m ³ /h with V = 50 %		350		490
V m ³ /h max.		650		850
Maximum recommended room size				
Fläche m ² (w/ V max (quadruple air exchange))		54		71
Sound power level				
LwA dB(A) (with V min.)		35		34
LwA dB(A) (with V = 50 %)		56		53
LwA dB(A) (with V max.)		69		66
Sound pressure level at 1m				
LpA dB(A) (with V min.)		27		26
LpA dB(A) (with V = 50 %)		48		45
LpA dB(A) (with V max.)		61		58
Power consumption				
W (with V min.)		4		4
W (with V = 50 %)		32		36
W (with V max.)		166		168
Filter concept		2-level / HEPA		2-level / HEPA
Course filter		ISO ePM10 70% (M6)		ISO ePM10 70% (M6)
High-performance filter		H14		H14
Rated current A		1.7		1.7
Voltage/frequency		230 V~, 50/60 Hz		230 V~, 50/60 Hz
Protection category IP		20		20
Weight in kg		35		40

AirPal Go 300 H / AirPal Go 600 H



Dimensions AirPal Go 300 H / AirPal Go 600 H

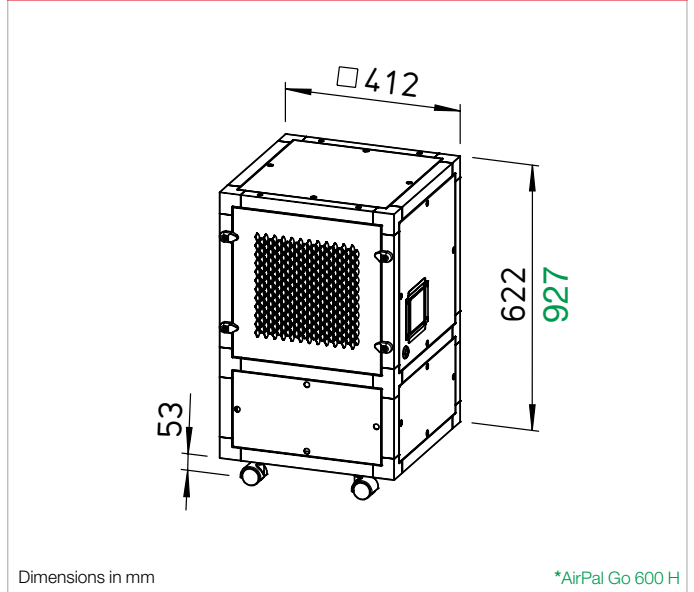

Mobile unit with air circulation for air purification of smaller individual rooms up to 50 m². Multiple units can be combined in larger rooms. Equipped with a 2-level filter concept incl. HEPA 14, 99.995 % of all viruses are removed from the room air.

■ Highlights

- Mobile air purifier with Hepa 14 filter technology.
- Two-level filter concept incl. coarse 65 % pre-filter and Hepa high-performance filter.
- Permanent filter-monitoring incl. filter replacement indication.
- Integrated timer for automatic operation according to weekly plan.

■ Filter concept and efficiency

The 2 level filter concept consists of 2 parallel pre-filters and efficient Hepa 14 high-performance filters. The pre-filter ensures the safe separation of larger particles, so that the Hepa14 filter is not contaminated and the service life is prolonged. the Hepa14 filter ensures the separation of 99.995 % of particles in the 0.3 µm range.

■ Plug & Play

The units are delivered preconfigured and fully assembled and they only require plugging in to a power socket.

■ Air exchange

Air purifiers must be designed on condition that sufficient air exchange is ensured. This depends on room size, number of persons, occupancy duration and activity level. We recommend at least quadruple air exchange. Further information on ideal air exchange can be found at AirPalSelect.com.

■ Acoustics

Quiet operation is ensured by the integrated silencers in casing as well as the sound-optimised air flow and arrangement of internal components.

■ Air inlet/outlet

The air inlet is located on both side

surfaces. The air outlet is positioned on the base side, so that unpleasant draughts are prevented.

■ Power control

The output can be variably adjusted to personal needs. An integrated timer allows automatic operation according to a programmable weekly plan. Both filters are individually pressure-monitored. Warning LEDs indicate dirty filters and necessary replacement.

■ Installation

The units are mobile and can be flexibly positioned due to the wheels.

■ Casing

Casing made of extruded aluminium profile and sandwich panels made of corrosion-resistant steel sheet. Quick and safe maintenance and filter replacement due to special side panel attachment system.

■ Fans

Low-noise EC high-performance fan with backward-curved impeller ensures maximum energy efficiency.

■ Replacement air filter (unit = 2pc)

For AirPal Go 300 H:
ELF-AirPal Go 300 H/Coarse 65%
 Ref. no. 40145
ELF-AirPal Go 300 H/Hepa 14
 Ref. no. 40146

For AirPal Go 600 H:
ELF-AirPal Go 600 H/Coarse 65%
 Ref. no. 40147
ELF-AirPal Go 600 H/Hepa 14
 Ref. no. 40148

Technical data				
Unit	AirPal Go 300 H	Ref. no. 00661	AirPal Go 600 H	
Output				
V m ³ /h min.	100		150	
V m ³ /h with V = 50 %	150		300	
V m ³ /h max.	300		600	
Maximum recommended room size				
Fläche m ² (w/ V max (quadruple air exchange))	25		50	
Sound power level				
LwA dB(A) (with V min.)	54		48	
LwA dB(A) (with V = 50 %)	56		59	
LwA dB(A) (with V max.)	62		69	
Sound pressure level at 1m				
LpA dB(A) (with V min.)	46		40	
LpA dB(A) (with V = 50 %)	48		51	
LpA dB(A) (with V max.)	54		61	
Power consumption				
W (with V min.)	3		8	
W (with V = 50 %)	8		19	
W (with V max.)	38		78	
Filter concept				
	2-level / HEPA		2-level / HEPA	
Course filter	ISO Coarse 65% (G4)		ISO Coarse 65% (G4)	
High-performance filter	H14		H14	
Rated current A	0.4		0.7	
Voltage/frequency	230 V~, 50/60 Hz		230 V~, 50/60 Hz	
Protection category IP	44		44	
Weight in kg	30		50	

We have even more in store: The Helios AntiVirus range.



Helios CO₂ monitors as indicators of air quality.



With increasing CO₂ concentrations, the amount of aerosols in the room air and thus the risk of viral infection increases – it is high time to ventilate! Maintain control now with the new Helios CO₂ monitors:

- At a glance: Traffic light display with five LEDs which provides information about the concentration of CO₂ content in the room air.
- Intelligent measurement range: The CO₂ values are measured from 0 to 3000 ppm (parts per million).
- Entirely maintenance-free: Helios CO₂ monitors are maintenance-free. Even the calibration is fully automated.

Ventilation with heat recovery for individual rooms.

Decentralised ventilation units KWL® Yoga.



Our new, **decentralised ventilation units with heat recovery KWL® Yoga** offer an optimal and particularly economical solution for preventing the spread of viruses via aerosols: The standard integrated CO₂ sensor ensures demand-based control and the fully automated and continuous air exchange without any user intervention. There is no need to install air ducts due to the decentralised design.

- In performance classes 400, 700 and 1,000 m³/h.
- For individual rooms e.g. classrooms, offices or meeting rooms.
- Ideally suitable for retrofitting due to decentralised design.

Energy-efficient compact ventilation units for new builds and renovations. Helios AIR1®.

The **energy-efficient compact ventilation units Helios AIR1** are another efficient solution for preventing the spread of Covid-19 as well as a safe and sustainable investment in the future. With three unit series, they offer different technical variants for virtually any requirement: for ceiling installation or floor-standing installation, with highly efficient cross counter-flow or rotary heat exchangers and for internal and external application.

- Sustainable efficiency – for new builds and renovations.
- Multi-level filter concept for pure, healthy air.
- For air flow rates from 500 to 15,000 m³/h.
- Central building solution for residential, commercial and industrial areas.

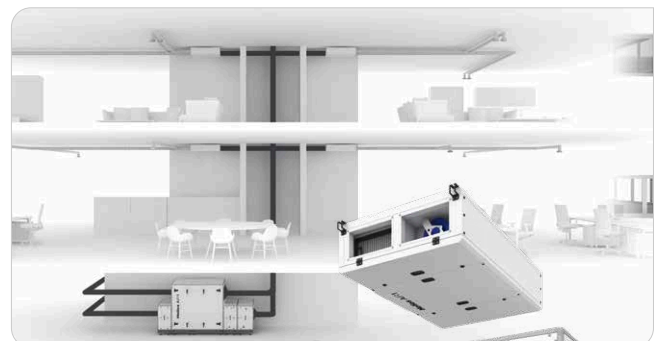

Our experts also present news in the field of ventilation as a preventative measure on our social media channels.

Connect with us:





Helios Ventilatoren GmbH + Co KG · Lupfenstraße 8 · 78056 Villingen-Schwenningen · Germany
Phone +49 77 20 / 606 - 0 · Fax +49 77 20 / 606 - 257 · export@heliosventilatoren.de · www.heliosventilatoren.de

Copyright ©: Helios Ventilatoren GmbH + Co KG, 78056 VS-Schwenningen, Germany. Certified according to ISO 9001/2015.
Subject to technical modifications. Illustrations and information are non-binding. Document no. 10024.844/03.21