

Complete kit, in-duct pump, for the condensate removal of air conditioners up to 10kW / 36000BTU.

Ref: DE05LC9460

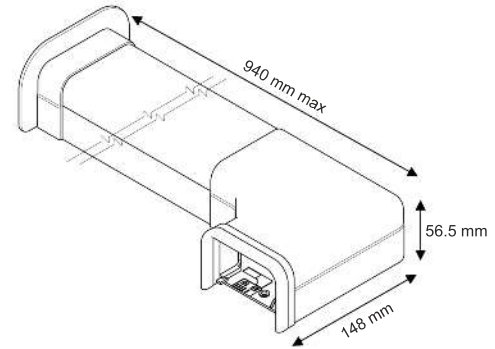
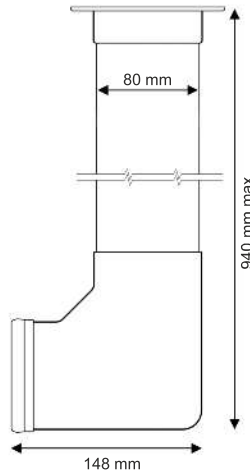

Hose diameter
Suction : 4/6 mm - supplied
Discharge : 6/9 mm - not supplied

SPECIFICATIONS

Flowrate max	15 l/h
Discharge head	10 m
Electrical power	19W
Voltage	220-240V 50/60Hz
Alarm	NO-NC
Noise level*	
Protection rating	IP64
Thermal protection	Yes
Operating cycle**	100%
Power / alarm cable	1.6 m
Trunking dimensions only	800 x 80 x 55 mm

* Notation from 1 wave (≤ 20 dBA) to 6 waves (> 45 dBA)

** The pump is able to run 100% of the time if necessary.

FLOWRATE

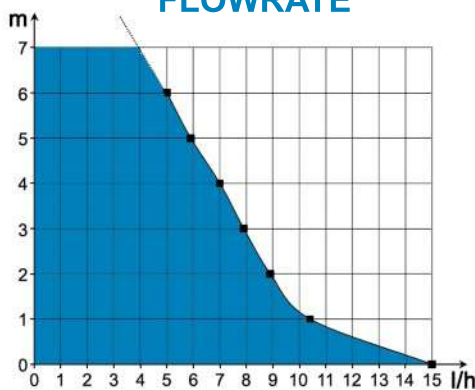

Recommended accessory



Connection extension kit

Allows the pump to be moved into a false ceiling, thus reducing the noise level.

Ref: GC1KCTC710

BENEFITS



mini FLOWATCH® 2 included

It assures a high reliability and an easy maintenance.



Very silent

Very silent pump (20.2 dBA), suitable for an installation in any room.



IP64 protection

Protected against water splashes and dust.



Stop siphoning included

Allows to avoid all risk of negative discharge and to secure the pump functioning over time.



Nice design

Thanks to its shape and its finishing accessories (included), FLOWATCH® DESIGN offers great aesthetics qualities.



Kit pre-assembled

Pump is already installed in its duct. Installation is easy and quick.

CONTENTS



Duct with elbow- Finishing gasket - Finishing ceiling plate - Pump in absorber bracket - Reservoir with air-vent tube - Power / alarm cable - Reservoir stand - Inlet tube - Suction tube 0.25m - Screws and rawlplugs