

WHR-R

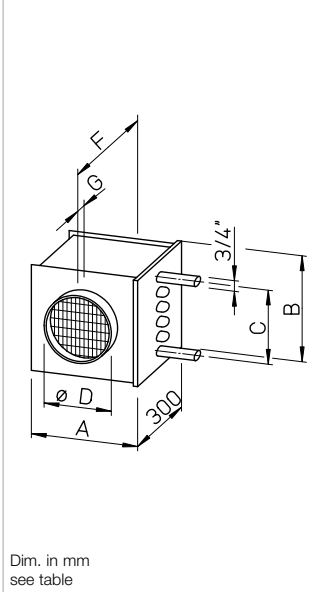

Dimensions WHR-R



Warm water heating element for installation in vent. ducts.

Dimensionally matched to the Helios round duct fans. Casing made of galvanised steel sheet. Double-sided connections with rubber lip seal for standard ducts. Air heater with aluminium blades, pressed onto copper pipes. Operating temp. t_{max} 100 °C. Operating pressure max. 8 bar. Water connection pipes with external thread. Two inspection covers on water connection side for easy cleaning. With drain/vent valve.

Installation instructions

Install the heating element in the flow direction downstream of the fan. In case of installation upstream of the fan, ensure that the air flow temperature at the fan does not exceed its maximum permissible temperature. In order to protect against contamination and to prevent a drop in performance, the installation of an air filter LFBR is recommended. A duct piece of at least 1 m in length must be installed between the fan and the heating element, so that a uniform flow is achieved. When installing a heating element, make sure that drainage and venting is ensured. Attention: Frost protection should be provided on site.

Selection

The effective temperature increase results from the parameters: Volume throughput, element output and flow temperature. These parameters can be determined using the adjacent diagrams (in steps a - c). The heat outputs are also specified in the type table for some volume parameters. When selecting a fan (volume determination), the pressure loss of the heating element, which is shown in the diagrams, must be taken into account (figure d).

Determination of press. loss

The diagrams above show the pressure loss depending on volume flow for the respective heating element.

Accessories	Page
Temperature control system WHST, WHS HE	483 f.

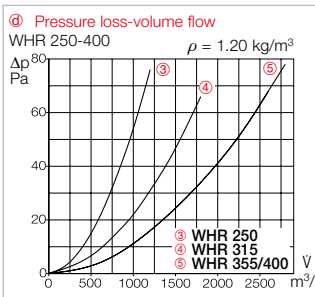
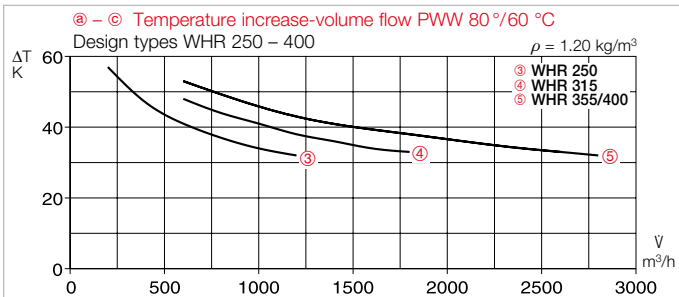
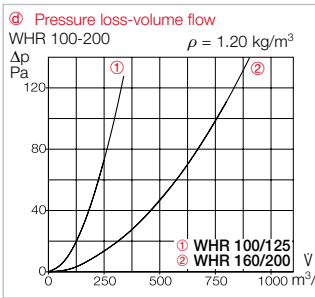
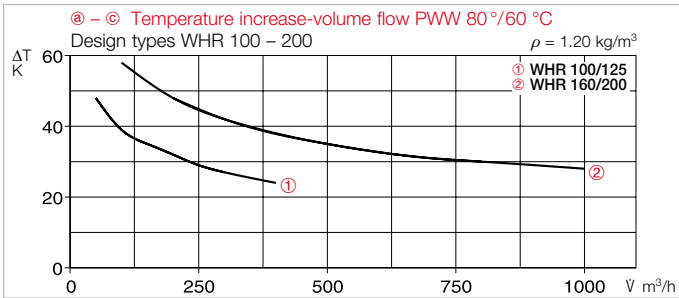

a) Temperature increase

Determination: $\Delta T = \vartheta_i - \vartheta_a$ [K]
 ΔT : Air temperature difference [K]
 ϑ_i : Air temp., air heater outlet [°C]
 ϑ_a : Air temp., air heater inlet [°C]

b) Volume throughput

Given by fan performance curve, whereby system resistances and heating element pressure loss (figure d) must be taken into account.

c) Determination of heat output

$$Q_H = \frac{V \cdot \Delta T \cdot c_{pL} \cdot \rho_L}{3600} \text{ [kW]}$$

V: Volume flow [m³/h]
 ΔT : Air temperature difference [K]
 c_{pL} : Specific heat capacity of the air (1.0) [kJ/kg K]
 ρ_L : Air density (1.2) [kg/m³]

Type	Ref. no.	Compat. with duct Ø mm	Air-side data					Water-side data ¹⁾		Dimensions						Connection d ²⁾	Weight ca. kg	Compatible temperature control system Type Ref. no.	
			Heat output kW ¹⁾	kW ²⁾	Δ T air K ¹⁾	K ²⁾	at V m³/h	Pressure loss Δ p _s kPa	at water volume l/h	A	B	C	Ø D	G	F				
WHR 100	09479	100	1.9	0.9	35	17	150	1	84	161	180	140	100	45	387	3/4	3.2	WHST 300 T38 ³⁾	08817
WHR 125	09480	125	2.6	1.1	29	13	250	2	115	161	180	140	125	45	387	3/4	3.2	WHST 300 T38 ³⁾	08817
WHR 160	09481	160	5.5	3.1	38	22	400	11	245	236	255	215	160	45	387	3/4	4.9	WHST 300 T38 ³⁾	08817
WHR 200	09482	200	7.2	4.1	33	19	600	17	317	236	255	215	200	45	387	3/4	4.9	WHST 300 T38 ³⁾	08817
WHR 250	09483	250	10.7	6	37	21	800	8	470	311	330	290	250	65	427	3/4	6.9	WHS HE	08319
WHR 315	09484	315	18.3	10.4	36.2	21	1400	9	810	396	405	365	315	56	410	3/4	9.0	WHS HE	08319
WHR 355	08790	355	24.5	14	38	21.6	1800	9	1080	461	480	420	355	56	410	3/4	12.5	WHS HE	08319
WHR 400	09524	400	26.2	15	36	21	2000	11	1060	461	480	420	400	71	440	3/4	12.5	WHS HE	08319

The values apply for supply air temperature 0 °C and flow/return temperatures: 1) 90/70 °C, 2) 60/40 °C.
⁴⁾ Alternative WHST 300 T50, see p 163 (Ref. no. 08820).

³⁾ 3/4" = 19.05 mm, 1" = 25.4 mm, external thread.