

BATHROOM EXTRACT FANS SILENT-100 Series

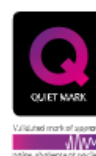

Range of axial extractors with airflow rates of 95 m³/h, for connection to 100 mm diameter circular ducting. Motor mounted on silent-elastic-blocks which absorb the vibrations and allow offering very low noise level. All the fans are manufactured from injection moulded plastic, fitted with automatic shutter and single phase 230V-50Hz, class B low consumption motor equipped with thermal overload protection. All the fans are class II insulation, IP45 rated and suitable to operate with air temperature up to 40°C.



WATER PROTECTED!



LOW NOISE!



ENERGY EFFICIENT!



SILVER version.



CHAMPAGNE version.



GOLD version.

The SILENT-100 Series can be supplied with an aesthetical SILVER, CHAMPAGNE or GOLD front grille.



Back draft shutter

To prevent air entry and limit heat leakage when the extractor is not operating. It opens due to the pressure of the air.



Silent-blocks

Motor mounted on "Silent-elastic-block" to prevent vibration and noise transmission.

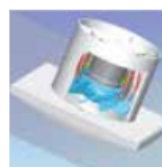

SILENT-100

Quiet operation

In usual extract fans the vibrations are transmitted to the surrounding areas while in SILENT extractor fans the vibrations are absorbed by the Silent Blocks.



USUAL EXTRACTOR

BATHROOM EXTRACT FANS

SILENT-100 Series



MODEL FEATURES

	CZ	CRZ	CRIZ	CHZ	CHZ VISUAL	CDZ	CZ 12V
PILOT LIGHT	•	•	•	•	•	•	•
BACKDRAFT SHUTTER	•	•	•	•	•	•	•
ADJUSTABLE RUN-ON-TIMER (1-30 MIN)		•		•	•	•	*
AUTOMATIC TIMER			•				
ADJUSTABLE HUMIDISTAT				•	•		
DETECTOR MOVEMENT						•	
BALL BEARINGS	•	•	•	•	•	•	•
WIRING DIAGRAM**	2, 3	4, 5	4, 5	1, 4	1, 4	1	6

* Using CT-12/14R transformer.

** See section of Wiring Diagrams.

PERFORMANCE CURVE

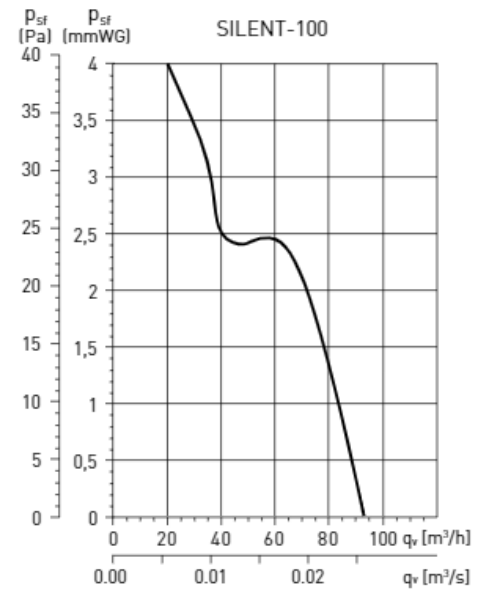

TECHNICAL CHARACTERISTICS

Model	Speed (rpm)	Abs. power at free discharge (W)	Voltage (V) 50 Hz	Sound pressure level* (dB(A))	Airflow at free discharge (m³/h)	Insulation/ IP	Ø duct (mm)	Weight (kg)
SILENT-100	2400	8	230	26,5	95	Class II / IP45	100	0,57
SILENT-100 12V	2320	13	12	26,5	95	Class III / IP57	100	0,57

* Sound pressure level measured at 3 m at free air conditions.

DIMENSIONS (mm)

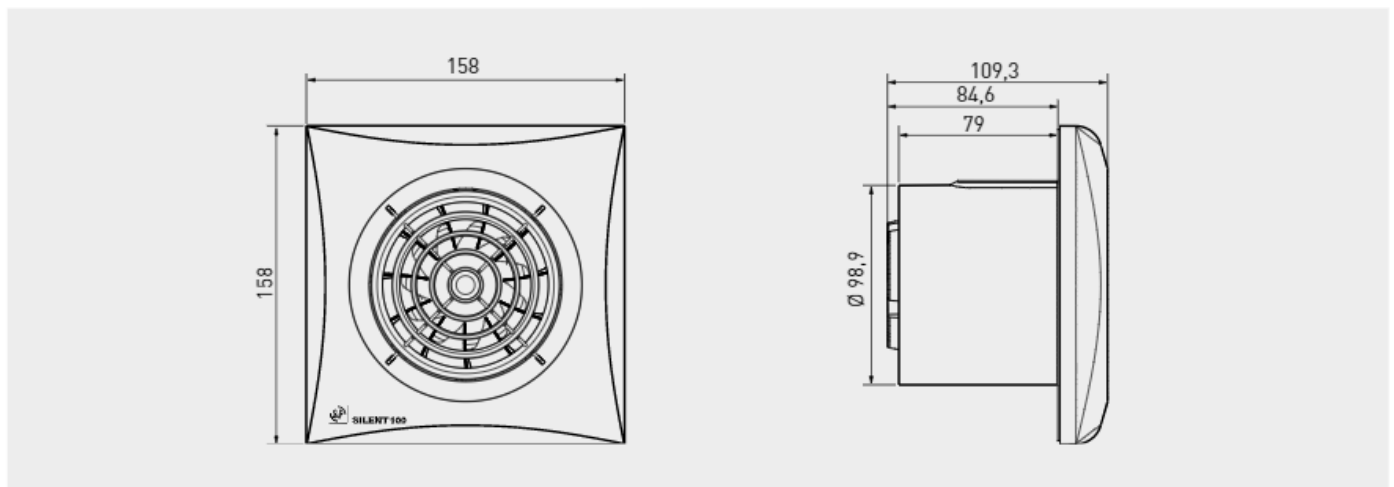

ACCESSORIES



GSA-M0 100
Flexible aluminium ducting.



GRA-75
Aluminium exterior grille.



WALL KIT
Fixed shutter and telescopic duct. (200 to 420 m).



CX-80/125
Worm drive ducting clip.



PER-100W
Back draft shutter.



WINDOW KIT 100
Accessory to allow SILENT-100 in a window.