

Performance Chart

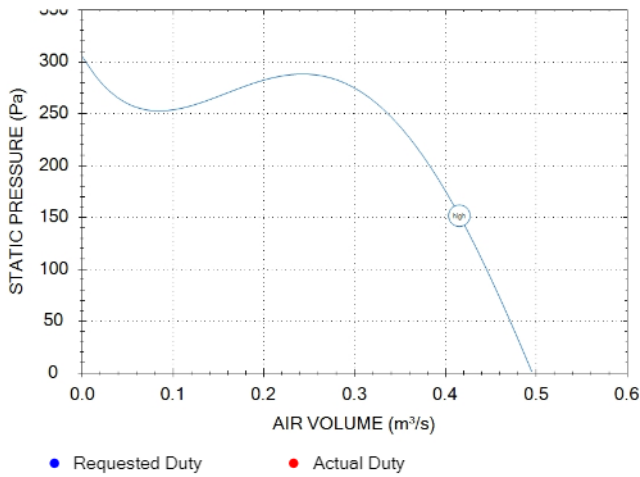

17110010

Tech Ref File:
 Stock Reference: 17110010
 Product Description: ACM250
 Product Type: Ventilation
 Product Range: In-Line Fans
 Impeller: Mixed Flow
 Casing: Galvanised sheet metal
 Speed: 2720 rpm
 Airstream Temperature: -5°C to 40°C
 dBA: 31
 Specific Fan Power & dB(A) shown are at duty point.

Warranty: 2 Years

Electrical Information

Supply Voltage: 220-240V/1/50Hz
 Full Load Current: 1 A
 Starting Current: 0.8 A
 Motor Poles: 2
 Motor IP Rating: IP54
 Speed Controllable: Yes

Acoustic Information

	63	125	250	500	1k	2k	4k	8k	Total	dBA@3m
Inlet	-	34	54	61	65	67	66	55	71	51
Outlet	-	39	64	68	71	70	66	55	76	55
Breakout	-	34	41	43	46	46	42	37	51	31

Sound Power Level Spectra dB (re 10⁻¹² Watts)

For ducted units, sound power is given as In Duct with end reflections added.
 Stated dB(A) levels at 3m with spherical propagation at a reference level of 2 x 10⁻¹² Pa

Optional Accessories

Part No	Description
400144	FLUSH FITTING METAL MOUNT
W300310	Electronic 1.5A Controller
10314103	3 AMP SINGLE PHASE CONTRO

Dimensions

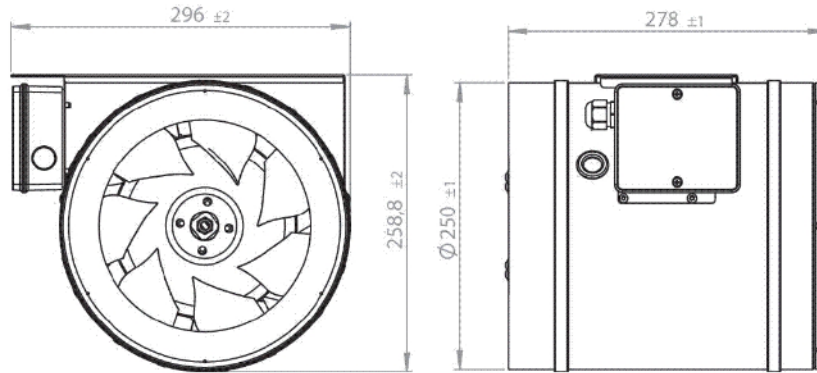

A	B	C	D	E	F	G	H
248	253	186	385	156	170	145	138

Dimensions shown in mm
Weights in kg

