

EuroSeries[®] (ESC)

- External rotor motors
- Die cast aluminium impellers
- Fully speed controllable
- Air Volumes up to 13.89m³/s
- Sizes 250 to 1000 protected to IP54
- Operating Temperatures from -40°C up to +70°C
- Motor Insulation Class F
- HOT SPOT Protection
- Reversible for supply or extract
- Tough epoxy paint finish
- Quality Assurance to BS EN ISO 9001:1994
- Performance tested to BS848 Part 1 1980



The EuroSeries[®] ESC Short Cased axial blade fans, feature a single shot die cast aluminium blade & external rotor motor design.

The EuroSeries[®] ESC range is available in eleven sizes with the extract performances up to 13.89m³/s, with pressure characteristics of up to 300Pa. All units are designed for & fully speed controllable.

Impellers

All sizes are supplied with cast aluminium impellers, ensuring performance when working against outdoor conditions and abrasive airflow.

Motors

External rotor motors are specially designed and styled for this range of fan. Ball bearings are greased for life. Rotors are dynamically balanced to ISO 1940. Sizes 250-1000mm, motors are protected to IP54, against dust and moisture complying with BS EN 60529:1992. They are ribbed aluminium body castings for efficient cooling. Motor insulation is Class 'F' (from -40°C to +70°C).

Electrical

Single phase 220-240V 50Hz. Capacitor start and run. Three phase 380-415V 50Hz. An IP54 terminal box are supplied with most models with 20mm and PGII entry. All motors are fitted with thermal overload Protection which should be wired into all controller circuits and into starter contactors. Models are available with either 2,4, 6 & 8 pole motors.

Terminal Box

Terminal Box to IP54 as standard, protected against dust and water from any angle allowing outside applications.

Performance

The fan performance is in accordance with tests to BS848 Part 1 1980.

Sound Levels

Fan sound levels, measured in a reverberant chamber in accordance with BS848 Part 2 1985. Published dB(A) figures are free field sound pressure levels at 3m with spherical propagation at a reference level of 2×10^5 Pa (20 micro-Pascal). The sound power level spectra figures are dB with reference level of 10^{12} Watts (1 pico-watt). To ensure minimum noise levels during speed control, an auto transformer speed control is recommended.

Accessories

A full range of accessories:

- Electronic Speed Controllers
- Auto Transformer Speed Controllers
- D.O.L. Starters & Overloads
- Ancillary Packs (comprising:- 4 AVM's, 2 mounting feet, 2 matching flanges, 2 flexible connectors + clips)
- Wire Guards
- Attenuators
- Mounting Feet
- Matching Flanges
- Anti Vibration Mounts
- Louvre Shutters

Dimensions (mm)

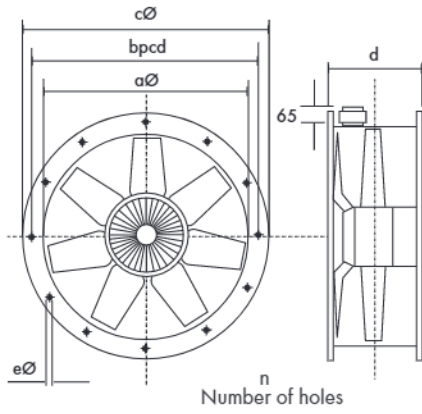

Dia	∅a	∅b	∅c	d	∅e	n	kg
250	254	286	306	110	7	8	5
315	316.5	356	382	135	9.5	8	6.1
355	356	395	421	135	9.5	8	7.1
400	400	438	466	155	9.5	12	8.1
450	451	487	515	160	9.5	12	13.4
500	503	541	567	166	9.5	12	15.7
560	559	605	635	210	11.5	16	20.1
630	634	674	707	220	11.5	16	44
710	711	751	785	260	11.5	16	31
800	797	837	871	280	11.5	24	39
1000	1001	1043	1080	330	11.5	24	73

Mounting Feet

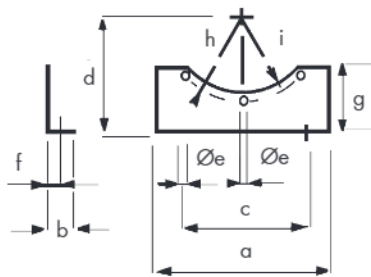

Stock Ref	a	b	c	d	∅e	f	g	h	i
MFZ315	315	40	265	200	10	20	71	178	166
MFZ355	350	40	300	225	10	20	81.5	198	186
MFZ400	250	40	220	250	10	20	78	219	205
MFZ450	275	40	240	275	10	20	82	244	230
MFZ500	315	50	280	315	1	25	100	271	255
MFZ560	355	50	320	355	12	25	97	303	285
MFZ630	400	50	360	400	12	25	109	337	320
MFZ710	465	50	415	450	12	25	119	376	362
MFZ800	458	50	420	518	12	25	176	419	405

Anti Vibration Mountings

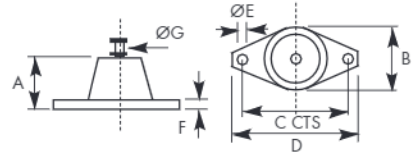

Stock Ref	A	B	C	D	∅E	F	∅G
68MP033G	27	37	54	67	7	3	M8

Coupling Flanges

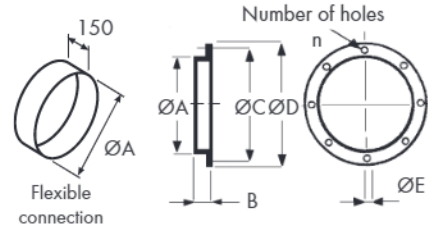

Stock Ref	∅A	B	∅C	∅D	∅E	n	Flexible Connection
CFZ315	313	40	356	382	10	8	FCZ315
CFZ355	353	40	395	421	10	8	FCZ355
CFZ400	398	45	438	466	10	12	FCZ400
CFZ450	448	45	487	515	10	12	FCZ450
CFZ500	498	45	541	567	10	12	FCZ500
CFZ560	558	45	605	635	12	16	FCZ560
CFZ630	628	45	674	707	12	16	FCZ630
CFZ710	708	50	751	785	12	16	FCZ710
CFZ800	798	50	837	871	12	24	FCZ800

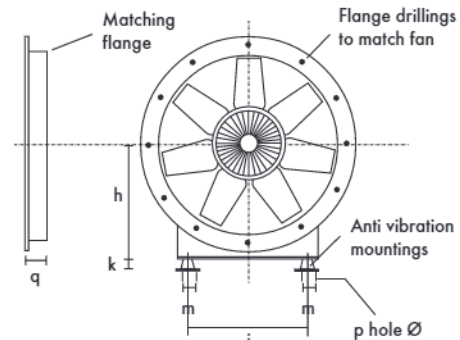

Unit size	h	i	k†	m	p∅	q
315	200	265	27	54	7	40
355	225	300	27	54	7	40
400	250	220	27	54	7	45
450	275	240	27	54	7	45
500	315	280	27	54	7	45
560	355	320	27	54	7	45
630	400	360	27	54	7	45
710	450	415	27	54	7	50
800	518	420	27	54	7	50

Performance Guide

250 to 315 dia. - 1 Phase - 2 & 4 Pole

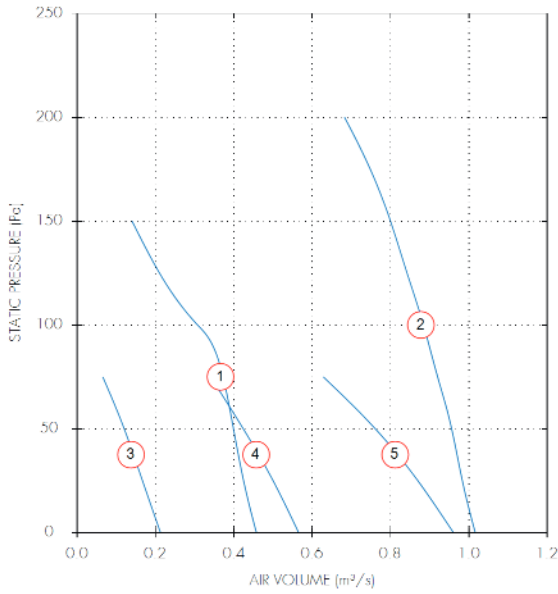

250 to 315 dia. - 3 Phase - 2 Pole

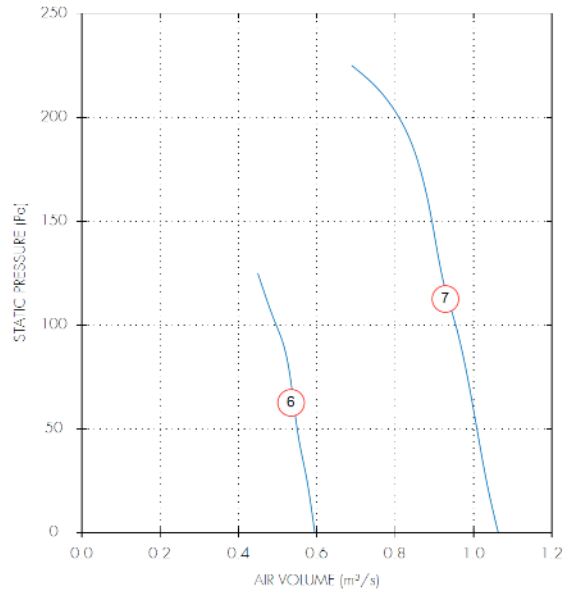

Dia.	Motor Phase	Stock Ref	Poles	r.p.m	IP Rating	Curve Ref.	m³/s @ Pa				Motor kW	S.C. Amps	F.L.C Amps	dB(A) @ 3m	
							0	50	100	150					200
250	1	ESC25012	2	2440	IP44	1	0.46	0.4	0.31	0.14		0.12	1.15	0.54	59
315	1	ESC31512	2	2690	IP54	2	1.02	0.96	0.88	0.8	0.68	0.56	7.2	2.4	64
250	1	ESC25014	4	1340	IP44	3	0.21	0.12				0.04	0.3	0.16	44
315	1	ESC31514	4	1300	IP54	4	0.57	0.42				0.15	1.38	0.7	50
355	1	ESC35514	4	1330	IP54	5	0.96	0.76				0.19	1.45	0.84	53
250	3	ESC25032	2	2700	IP44	6	0.59	0.55	0.5			0.2	3.5	0.87	61
315	3	ESC31532	2	2800	IP54	7	1.06	1.01	0.95	0.89	0.81	0.48	5	0.9	60

For Fans wired to reverse run, duty reduced by 30%
 ESC25012, ESC31512 and ESC25014 not suitable for reverse airflow

Sound Power Level Spectra dB (ref 10⁻¹² Watts)

Dia.	Motor Phase	Stock Ref	Poles	Spectrum	dB(A) @ 3m								
					63	125	250	500	1k	2k	4k	8k	
250	1	ESC25012	2	Inlet	69	70	76	76	70	70	67	59	57
250	1	ESC25012	2	Outlet	69	70	76	76	70	70	67	59	57
315	1	ESC31512	2	Inlet	69	73	79	74	74	76	73	66	61
315	1	ESC31512	2	Outlet	69	73	79	74	74	76	73	66	61
250	1	ESC25014	4	Inlet	70	72	63	58	54	52	45	35	41
250	1	ESC25014	4	Outlet	70	72	63	58	54	52	45	35	41
315	1	ESC31514	4	Inlet	70	68	66	61	60	62	58	51	47
315	1	ESC31514	4	Outlet	70	68	66	61	60	62	58	51	47
355	1	ESC35514	4	Inlet	65	70	67	65	64	64	62	55	50
355	1	ESC35514	4	Outlet	65	70	67	65	64	64	62	55	50
250	3	ESC25032	2	Inlet	69	70	75	79	74	70	66	60	59
250	3	ESC25032	2	Outlet	70	75	79	74	70	66	60	60	56
315	3	ESC31532	2	Inlet	71	72	83	80	78	79	75	67	64
315	3	ESC31532	2	Outlet	71	72	83	80	78	79	75	67	64

Performance Guide

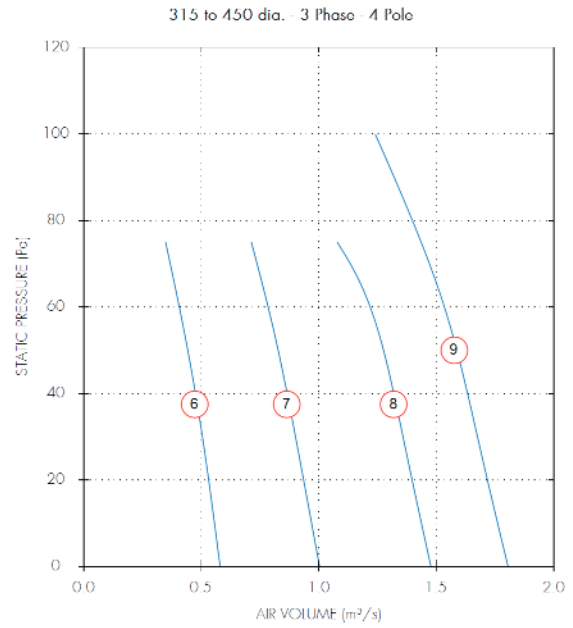
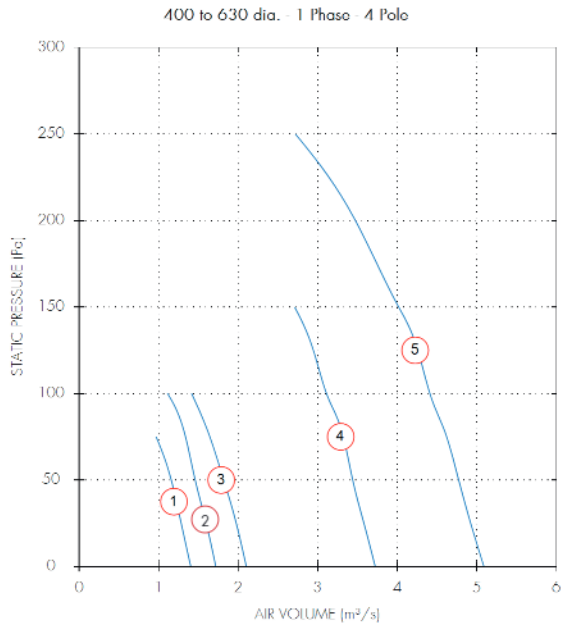

Dia.	Motor Phase	Stock Ref	Poles	r.p.m	IP Rating	Curve Ref.	m³/s @ Pa					Motor kW	S.C. Amps	F.L.C Amps	dB(A) @ 3m
							0	50	100	150	200				
400	1	ESC40014	4	1350	IP54	1	1.4	1.16				0.29	2.4	1.45	56
450	1	ESC45014	4	1370	IP54	2	1.72	1.46	1.11			0.36	3.6	1.6	61
500	1	ESC50014	4	1290	IP54	3	2.1	1.82	1.41			0.51	4.3	2.3	55
560	1	ESC56014	4	1320	IP54	4	3.72	3.44	3.11	2.71		1.4	9.3	6	63
630	1	ESC63014	4	1320	IP54	5	5.09	4.77	4.41	4.02	3.47	2.2	28	9.9	70
315	3	ESC31534	4	1390	IP54	6	0.58	0.44				0.11	2.1	0.27	46
355	3	ESC35534	4	1370	IP54	7	1	0.83				0.17	1.35	0.37	49
400	3	ESC40034	4	1350	IP54	8	1.48	1.27				0.26	2.1	0.56	51
450	3	ESC45034	4	1380	IP54	9	1.8	1.59	1.24			0.36	2.6	0.8	56

For Fans wired to reverse run, duty reduced by 30%

Sound Power Level Spectra dB (ref 10⁻¹² Watts)

Dia.	Motor Phase	Stock Ref	Poles	Spectrum	dB(A) @ 3m								
					63	125	250	500	1k	2k	4k	8k	
400	1	ESC40014	4	Inlet	70	72	67	66	65	65	64	56	51
400	1	ESC40014	4	Outlet	70	72	67	66	65	65	64	56	51
450	1	ESC45014	4	Inlet	69	76	73	72	70	71	70	62	57
450	1	ESC45014	4	Outlet	69	76	73	72	70	71	70	62	57
500	1	ESC50014	4	Inlet	65	75	69	70	70	71	69	62	56
500	1	ESC50014	4	Outlet	65	75	69	70	70	71	69	62	56
560	1	ESC56014	4	Inlet	100	90	89	84	82	79	75	68	67
560	1	ESC56014	4	Outlet	100	90	89	84	82	79	75	68	67
630	1	ESC63014	4	Inlet	82	86	79	79	80	78	75	70	64
630	1	ESC63014	4	Outlet	82	86	79	79	80	78	75	70	64
315	3	ESC31534	4	Inlet	64	67	69	63	62	60	58	53	47
315	3	ESC31534	4	Outlet	64	67	69	63	62	60	58	53	47
355	3	ESC35534	4	Inlet	58	73	63	64	64	65	64	58	50
355	3	ESC35534	4	Outlet	58	73	63	64	64	65	64	58	50
400	3	ESC40034	4	Inlet	62	73	65	65	67	69	67	60	53
400	3	ESC40034	4	Outlet	62	73	65	65	67	69	67	60	53
450	3	ESC45034	4	Inlet	65	82	75	76	73	72	69	62	58
450	3	ESC45034	4	Outlet	65	82	75	76	73	72	69	62	58

Performance Guide

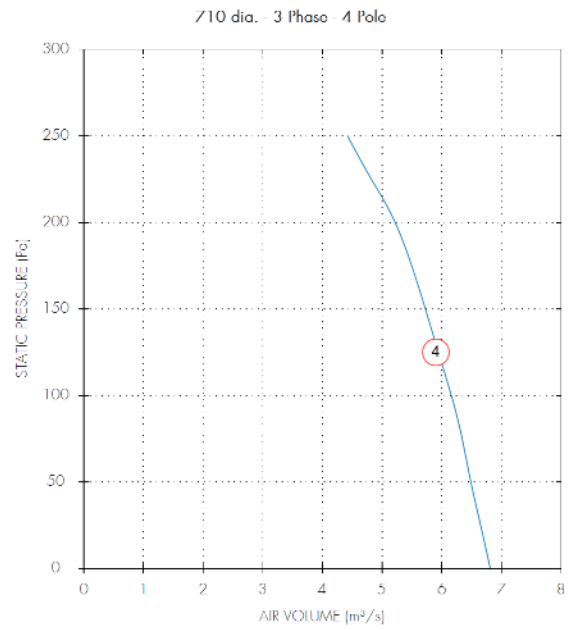
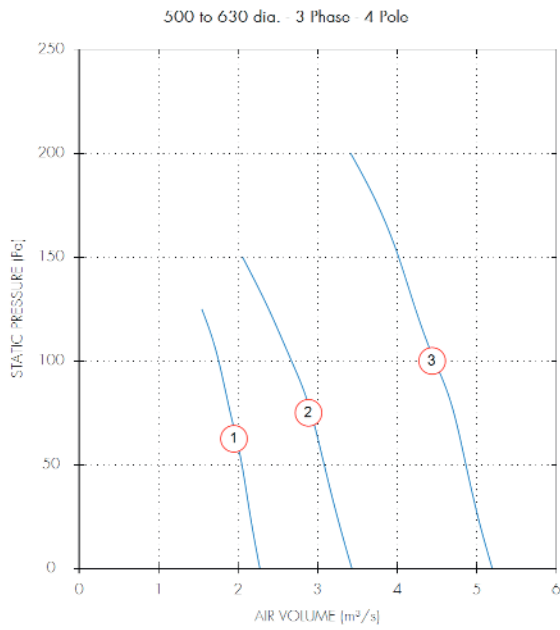

Dia.	Motor Phase	Stock Ref	Poles	r.p.m	IP Rating	Curve Ref.	m³/s @ Pa					Motor kW	S.C. Amps	F.L.C Amps	dB(A) @ 3m
							0	50	100	150	200				
500	3	ESC50034	4	1380	IP54	1	2.27	2.05	1.75			0.55	4.2	1.05	58
560	3	ESC56034	4	1220	IP54	2	3.43	3.08	2.67	2.05		1.25	7.7	2.2	70
630	3	ESC63034	4	1360	IP54	3	5.19	4.86	4.47	4.02	3.41	1.9	14	3.2	64
710	3	ESC71034	4	1290	IP54	4	6.81	6.49	6.16	5.72	5.22	2.9	19	5.3	72

For Fans wired to reverse run, duty reduced by 30%

Sound Power Level Spectra dB (ref 10⁻¹² Watts)

Dia.	Motor Phase	Stock Ref	Poles	Spectrum	dB(A) @ 3m								
					63	125	250	500	1k	2k	4k	8k	
500	3	ESC50034	4	Inlet	67	71	69	72	70	71	68	61	56
500	3	ESC50034	4	Outlet	67	71	69	72	70	71	68	61	56
560	3	ESC56034	4	Inlet	85	79	77	76	76	75	72	66	61
560	3	ESC56034	4	Outlet	85	79	77	76	76	75	72	66	61
630	3	ESC63034	4	Inlet	71	88	82	83	82	81	78	72	67
630	3	ESC63034	4	Outlet	71	88	82	83	82	81	78	72	67
710	3	ESC71034	4	Inlet	80	87	86	88	89	86	83	79	72
710	3	ESC71034	4	Outlet	80	87	86	88	89	86	83	79	72

Performance Guide

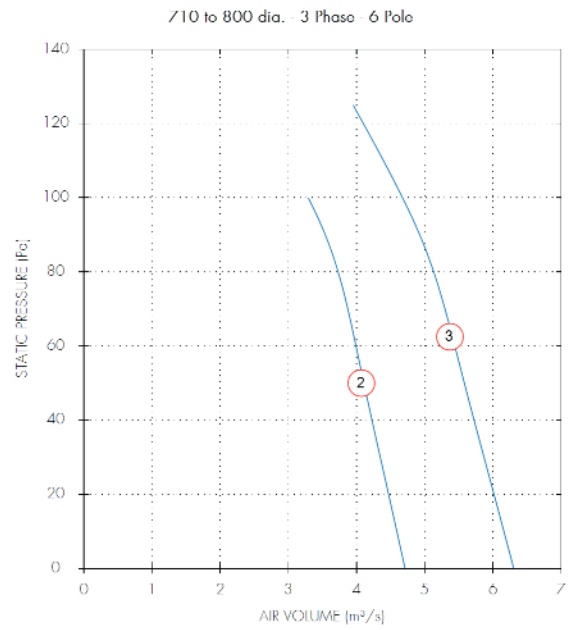
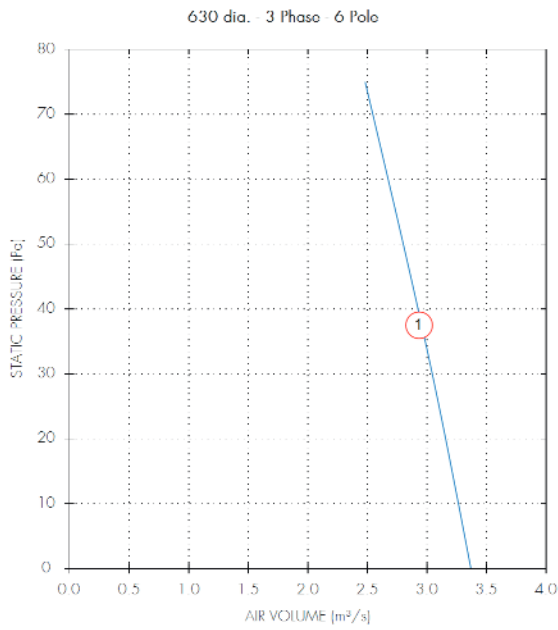

Dia.	Motor Phase	Stock Ref	Poles	r.p.m	IP Rating	Curve Ref.	m ³ /s @ Pa						Motor kW	S.C. Amps	F.L.C Amps	dB(A) @ 3m
							0	25	50	75	100	125				
630	3	ESC63036	6	890	IP54	1	3.37	3.1	2.8	2.48		0.59	3.6	1.3	59	
710	3	ESC71036	6	860	IP54	2	4.71	4.41	4.11	3.8	3.29	1.1	7.7	2.2	62	
800	3	ESC80036	6	900	IP54	3	6.3	5.94	5.58	5.22	4.67	1.4	9.8	2.7	64	

For Fans wired to reverse run, duty reduced by 30%

Sound Power Level Spectra dB (ref 10⁻¹² Watts)

Dia.	Motor Phase	Stock Ref	Poles	Spectrum	dB(A) @ 3m								
					63	125	250	500	1k	2k	4k	8k	
630	3	ESC63036	6	Inlet	67	78	76	74	73	72	77	59	60
630	3	ESC63036	6	Outlet	67	78	76	74	73	72	77	59	60
710	3	ESC71036	6	Inlet	80	77	78	75	76	75	70	64	60
710	3	ESC71036	6	Outlet	80	77	78	75	76	75	70	64	60
800	3	ESC80036	6	Inlet	75	75	73	71	72	70	64	57	56
800	3	ESC80036	6	Outlet	75	75	73	71	72	70	64	57	56

Models & Accessories

Fan Stock Ref	Speed Controller			Overload Stock Ref	Fan Stock Ref	Speed Controller
	Electronic Stock Ref	Auto Transfor. Stock Ref	Starter Stock Ref			Auto Transfor. Stock Ref
1 Phase 2 Pole					3 Phase 2 Pole	
ESC25012	SP5001	SPM5020	444744	444699	ESC25032	RDTK10
ESC31512	SP5025	SPM5035	444744	444701	ESC31532	RDTK10
1 Phase 4 Pole					3 Phase 4 Pole	
ESC25014	SP5001	SPM5020	444744	444696		
ESC31514	SP5001	SPM5020	444744	444699	ESC31534	RDTK10
ESC35514	SP5001	SPM5020	444744	444699	ESC35534	RDTK10
ESC40014	SP5025	SPM5020	444744	444701	ESC40034	RDTK10
ESC45014	SP5025	SPM5035	444744	444701	ESC45034	RDTK10
ESC50014	SP5025	SPM5035	444744	444702	ESC50034	RDTK20
ESC56014*	-	-	444744	444704	ESC56034	RDTK40
ESC63014	-	SPM5140	444744	444706	ESC63034	RDTK40
					ESC71034	RDTK70
					3 Phase 6 Pole	
					ESC63036	RDTK20
					ESC71036	RDTK40
					ESC80036	RDTK40
					ESC100036*	-

*Not suitable for voltage speed control. Inverter speed control with sine filters only.

Size	1D Long - No Pod		1D Long - With Pod		2D Long - No Pod		2D Long - With Pod	
	Stock Ref	Stock Ref	Stock Ref	Stock Ref	Stock Ref	Stock Ref	Stock Ref	Stock Ref
250	ACZ2501D	-	-	-	ACZ2502D	-	-	-
315	ACZ3151D	-	ACZ3151DP	-	ACZ3152D	-	ACZ3152DP	-
355	ACZ3551D	-	ACZ3551DP	-	ACZ3552D	-	ACZ3552DP	-
400	ACZ4001D	-	ACZ4001DP	-	ACZ4002D	-	ACZ4002DP	-
450	ACZ4501D	-	ACZ4501DP	-	ACZ4502D	-	ACZ4502DP	-
500	ACZ5001D	-	ACZ5001DP	-	ACZ5002D	-	ACZ5002DP	-
560	ACZ5601D	-	ACZ5601DP	-	ACZ5602D	-	ACZ5602DP	-
630	ACZ6301D	-	ACZ6301DP	-	ACZ6302D	-	ACZ6302DP	-
710	ACZ7101D	-	ACZ7101DP	-	ACZ7102D	-	ACZ7102DP	-
800	ACZ8001D	-	ACZ8001DP	-	ACZ8002D	-	ACZ8002DP	-

Starter Stock Ref	Overload Stock Ref	Ancillary Packs Stock Ref	Mounting Feet (pair) Stock Ref	Matching Flanges (each) Stock Ref	Wire Guards (each) Stock Ref	Anti-Vibration Mounts (set of 4) Stock Ref
444747	444699	APZ250	MFZ250	CFZ250	WGZ250	68MP033G
444747	444700	APZ315	MFZ315	CFZ315	WGZ315	68MP033G
		APZ250	MFZ250	CFZ250	WGZ250	68MP033G
444747	444697	APZ315	MFZ315	CFZ315	WGZ315	68MP033G
444747	444698	APZ355	MFZ355	CFZ355	WGZ355	68MP033G
444747	444699	APZ400	MFZ400	CFZ400	WGZ400	68MP033G
444747	444699	APZ450	MFZ450	CFZ450	WGZ450	68MP033G
444747	444700	APZ500	MFZ500	CFZ500	WGZ500	68MP033G
444747	444701	APZ560	MFZ560	CFZ560	WGZ560	68MP033G
444747	444702	APZ630	MFZ630	CFZ630	WGZ630	68MP033G
444747	444703	APZ710	MFZ710	CFZ710	WGZ710	68MP033G
444747	444700	APZ630	MFZ630	CFZ630	WGZ630	68MP033G
444747	444702	APZ710	MFZ710	CFZ710	WGZ710	68MP033G
444747	444702	APZ800	MFZ800	CFZ800	WGZ800	68MP033G

- Note:
- The Standard roof cowl colour is BS 00A 05 (Goose Wing Grey) for all special B.S. or RAL colours contact Vent-Axia.
 - When speed control is required a 5 step auto transformer speed controller is recommended, to ensure low noise levels.
 - All 3 phase models are suitable for frequency inverter speed control.
 - Vent-Axia only recommends using inverters with integral sine filters for reliable operation.